

RACAL INSTRUMENTS™

1260-16

POWER SWITCHING

PUBLICATION NO. 980673-023

EADS North America Defense Test and Services, Inc.
4 Goodyear, Irvine, CA 92618
Tel: (800) 722-2528, (949) 859-8999; Fax: (949) 859-7139

info@eads-nadefense.com
sales@eads-nadefense.com
helpdesk@eads-nadefense.com
<http://www.eads-nadefense.com>



PUBLICATION DATE: June 29, 1998

Copyright 1994 by EADS North America Defense Test and Services, Inc. Printed in the United States of America. All rights reserved. This book or parts thereof may not be reproduced in any form without written permission of the publisher.

**THANK YOU FOR PURCHASING THIS
EADS NORTH AMERICA DEFENSE TEST AND SERVICES PRODUCT**

For this product, or any other EADS North America Defense Test and Services, Inc. product that incorporates software drivers, you may access our web site to verify and/or download the latest driver versions. The web address for driver downloads is:

<http://www.eads-nadefense.com/downloads>

If you have any questions about software driver downloads or our privacy policy, please contact us at

info@eads-nadefense.com

WARRANTY STATEMENT

All EADS North America Defense Test and Services, Inc. products are designed and manufactured to exacting standards and in full conformance to EADS ISO 9001:2000 processes.

This warranty does not apply to defects resulting from any modification(s) of any product or part without EADS North America Defense Test and Services, Inc. express written consent, or misuse of any product or part. The warranty also does not apply to fuses, software, non-rechargeable batteries, damage from battery leakage, or problems arising from normal wear, such as mechanical relay life, or failure to follow instructions.

This warranty is in lieu of all other warranties, expressed or implied, including any implied warranty of merchantability or fitness for a particular use. The remedies provided herein are buyer's sole and exclusive remedies.

For the specific terms of your standard warranty, or optional extended warranty or service agreement, contact your EADS North America Defense Test and Services, Inc. customer service advisor. Please have the following information available to facilitate service.

1. Product serial number
2. Product model number
3. Your company and contact information

You may contact your customer service advisor by:

E-Mail:	Helpdesk@eads-nadefense.com	
Telephone:	+1 800 722 3262	(USA)
Fax:	+1 949 859 7309	(USA)

RETURN of PRODUCT

Authorization is required from EADS North America Defense Test and Services, Inc. before you send us your product for service or calibration. Call or contact the Customer Support Department at 1-800-722-3262 or 1-949-859-8999 or via fax at 1-949-859-7139. We can be reached at: helpdesk@eads-nadefense.com.

PROPRIETARY NOTICE

This document and the technical data herein disclosed, are proprietary to EADS North America Defense Test and Services, Inc., and shall not, without express written permission of EADS North America Defense Test and Services, Inc., be used, in whole or in part to solicit quotations from a competitive source or used for manufacture by anyone other than EADS North America Defense Test and Services, Inc. The information herein has been developed at private expense, and may only be used for operation and maintenance reference purposes or for purposes of engineering evaluation and incorporation into technical specifications and other documents which specify procurement of products from EADS North America Defense Test and Services, Inc.

DISCLAIMER

Buyer acknowledges and agrees that it is responsible for the operation of the goods purchased and should ensure that they are used properly and in accordance with this handbook and any other instructions provided by Seller. EADS North America Defense Test and Services, Inc. products are not specifically designed, manufactured or intended to be used as parts, assemblies or components in planning, construction, maintenance or operation of a nuclear facility, or in life support or safety critical applications in which the failure of the EADS North America Defense Test and Services, Inc. product could create a situation where personal injury or death could occur. Should Buyer purchase EADS North America Defense Test and Services, Inc. product for such unintended application, Buyer shall indemnify and hold EADS North America Defense Test and Services, Inc., its officers, employees, subsidiaries, affiliates and distributors harmless against all claims arising out of a claim for personal injury or death associated with such unintended use.

FOR YOUR SAFETY

Before undertaking any troubleshooting, maintenance or exploratory procedure, read carefully the **WARNINGS** and **CAUTION** notices.



CAUTION
RISK OF ELECTRICAL SHOCK
DO NOT OPEN



This equipment contains voltage hazardous to human life and safety, and is capable of inflicting personal injury.



If this instrument is to be powered from the AC line (mains) through an autotransformer, ensure the common connector is connected to the neutral (earth pole) of the power supply.



Before operating the unit, ensure the conductor (green wire) is connected to the ground (earth) conductor of the power outlet. Do not use a two-conductor extension cord or a three-prong/two-prong adapter. This will defeat the protective feature of the third conductor in the power cord.



Maintenance and calibration procedures sometimes call for operation of the unit with power applied and protective covers removed. Read the procedures and heed warnings to avoid “live” circuit points.

Before operating this instrument:

1. Ensure the proper fuse is in place for the power source to operate.
2. Ensure all other devices connected to or in proximity to this instrument are properly grounded or connected to the protective third-wire earth ground.

If the instrument:

- fails to operate satisfactorily
- shows visible damage
- has been stored under unfavorable conditions
- has sustained stress

Do not operate until performance is checked by qualified personnel.

Racal Instruments

EC Declaration of Conformity

We

Racal Instruments Inc.
4 Goodyear Street
Irvine, CA 92718

declare under sole responsibility that the

1260-16 Power Switching Module
P/N 407348

conforms to the following Product Specifications:

Safety: EN 61010-1

EMC: CISPR 11:1990/EN 55011 (1991): Group 1 Class A
IEC 801-2:1991/EN 50082-1 (1992): 4 kV CD, 8 kV AD
IEC 801-3:1984/EN 50082-1 (1992): 3 V/m, 27-500 MHz
IEC 801-4:1988/EN 50082-1 (1992): 1 kV

Supplementary Information:

The above specifications are met when the product is installed in a Racal Instruments certified mainframe with faceplates installed over all unused slots, as applicable.

The product herewith complies with the requirements of the Low Voltage Directive 73/23/EEC and the EMC Directive 89/336/EEC.

Irvine, CA, January 24, 1996

Quality Manager

This page was left intentionally blank.

NOTE FOR SYSTEMS WITH 1260-OPT 01T

The "Module-Specific Syntax" section of this manual shows the command syntax for the 1260-01S Smart Card. If you are using the newer 1260-01T Smart Card, the commands will NOT work as shown.

Consult the 1260-01T Manual for a description of the commands which may be used with the 1260-01T Smart Card.

The channel numbers described in this manual are valid for the 1260-01T. The channel numbers continue to be used for the 1260-01T.

The syntax of the commands which use channel numbers has changed for those cards controlled by the 1260-01T.

The new syntax used to close a channel is:

```
CLOSE (@ <module address> ( <channel> ) )
```

For example, with for a relay module whose <module address> is set to 7, closing <channel> 0 is performed with the command:

```
CLOSE (@ 7 (0))
```

Using the older 1260-01S, the command would be (as shown in this manual):

```
CLOSE 7.0
```

Many other command syntax differences exist. Please consult chapter 2 of the 1260-01T manual for a description of the commands which are available for the 1260-01T.

Control Information for the 1260-16

The following information describes the control-register-to-relay-channel mapping for a 1260-16 Relay Module. This information may be used to control a 1260-16 when using a 1260-01T in the register-based mode of operation.

Each relay on this module is controlled by setting or clearing a single bit within a Control Register. Control Registers on the module operate 8 channels simultaneously. There are eight control bits per Control Register. Setting the bit to a 1 closes the relay; setting the bit to a 0 opens the relay.

The table below shows the mapping from logical channels to control bits. The logical channels are used when operating the relay module in message-based mode. The control bits within the Control Registers are used to operate the module in register-based mode.

Each Control Register is located 2 addresses from the previous Control Register. That is, each Control Register is located at an odd address. This is shown in Table 2-2 of the 1260-01T manual. Control Register 0 is located at the "Base A24 Address" for the module. Consult the "Register-Based Operation" Section of Chapter 2 of the 1260-01T manual for a description of calculating control register addresses.

Channel	Control Register	Control Bit
0	0	0
1	0	1
2	0	2
3	0	3
4	0	4
5	0	5
6	0	6
7	0	7
8	1	0
9	1	1
10	1	2
11	1	3
12	1	4
13	1	5
14	1	6
15	1	7
16	2	0
17	2	1
18	2	2
19	2	3
20	2	4
21	2	5
22	2	6
23	2	7
24	3	0
25	3	1
26	3	2
27	3	3
28	3	4
29	3	5
30	3	6
31	3	7
32	4	0
33	4	1
34	4	2
35	4	3
36	4	4
37	4	5
38	4	6
39	4	7

Table Of Contents

Chapter 1	1-1
MODULE SPECIFICATION	1-1
Module Specification	1-1
Specifications	1-2
Ordering Information.....	1-3
Safety.....	1-3
Product Support.....	1-3
Pin Configuration	1-3
Chapter 2	2-1
INSTALLATION INSTRUCTIONS	2-1
Unpacking and Inspection	2-1
Reshipment Instructions.....	2-1
Option 01 Installation.....	2-2
Module Installation	2-2
Chapter 3	3-1
MODULE SPECIFIC SYNTAX	3-1
1260-16 Module Specific Syntax.....	3-1
Syntax.....	3-1
CLOSE and OPEN Command	3-1
PSETUP Command	3-2
PDATAOUT Command	3-2

Chapter 4	4-1
MODULE CONFIGURATION	4-1
General	4-1
Connector Pin Configuration	4-2
Chapter 5	5-1
OPTIONAL HARNESS ASSEMBLIES.....	5-1
Chapter 6	6-1
PRODUCT SUPPORT	6-1
Product Support	6-1
Warranty.....	6-1

List Of Figures

Figure 1-1, 1260-161-1

Figure 1-2, 1260-16 Pin Configuration.....1-4

Figure 4-1, 1260-16 Relay Diagram.....4-1

Figure 4-2, 1260-16 J200-J202 Pin Configuration4-3

Figure 4-3, 1260-16 Channel4-4

Figure 4-4, 1260-16 Components Per Channel4-5

Figure 4-5, 1260-16 Jumper Locations4-7

List Of Tables

Table 4-1, 1260-16 "COM, NO and NC" Assignments.....4-2

This page was left intentionally blank.

Chapter 1

MODULE SPECIFICATION

Module Specification

The 1260-16 Power Switching module provides 40 independent channels of SPDT switching. Each channel functions independently with all paths accessible through the front panel connectors. Every channel features mounting holes on the printed circuit board to allow for the addition of one series and two shunt elements. This permits components, such as fuses and arc suppressers (for contact protection), or resistors and capacitors (for filter circuits) to be installed. The circuit board also provides mounting holes for jumpers to allow up to eight common channels to be multiplexed. The module permits switching currents of up to 5 amps at 30 volts DC or 250 volts RMS per channel.

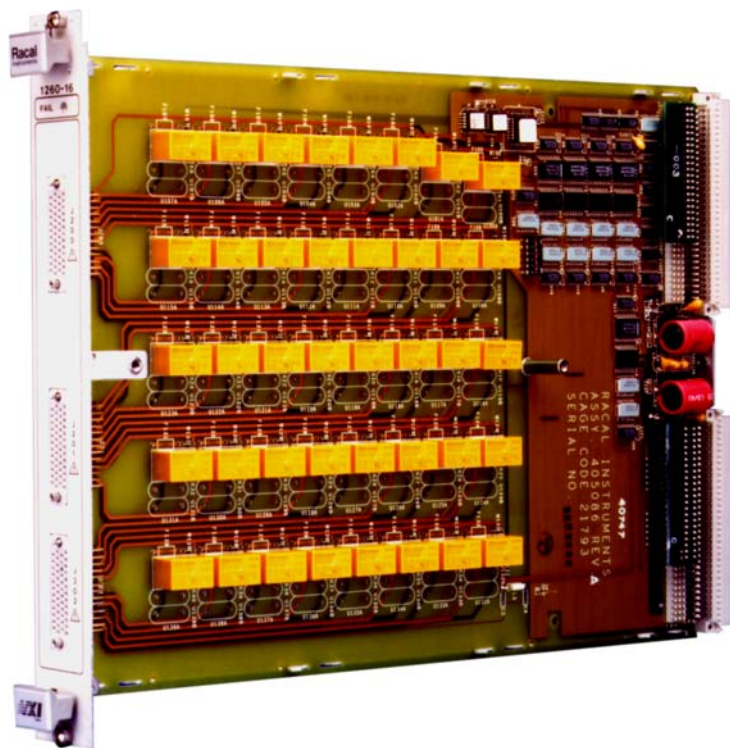

Figure 1-1, 1260-16

Specifications

Switch Configuration	40 SPDT Relays
User Connector	Positronics SMPL 4 FOTO LB
Maximum Switchable Voltage	125 V DC, 250 VAC RMS
Maximum Switchable Current Per Channel	5 A DC or AC RMS
Maximum Switchable Power Per Channel	150 W or 1250 VA
Maximum Switchable Power Per Module	1500 W or 12500 VA
Path Resistance	< 200 milliohms
Capacitance Per Independent Channel Open Channel	< 100 pF
Bandwidth, 50 Ω Termination	> 30 MHz
Isolation, 50 Ω Termination	30 dB to 100 kHz 20 dB to 1 MHz 15 dB to 10 MHz
Crosstalk, 50 Ω Termination	< -40 dB to 100 kHz < -35 dB to 1 MHz < -15 dB to 10 MHz
Switching Time	10 milliseconds
Cooling Requirements	
Airflow	1.0 liter/sec
Backpressure	0.05 mm of H ₂ O
Cooling Requirements (With Option 01S/T)	
Airflow	2.0 liters/sec
Backpressure	0.2 mm of H ₂ O
Power Requirements (I _{pm})	+5 V w/o Option 01 = 400 mA +5 V with Option 01 = 2.5A +24 V = 10 mA per relay
Weight	1.26 kg (2.77 lbs) without Option 01 1.41 kg (3.11 lbs) with Option 01
Minimum Firmware Revision Option 01	22.1

Ordering Information

Module Number	Description	Part Number
1260-16	40-Channel SPDT Switch, 5 Amp	407348

Safety

Refer to the "**FOR YOUR SAFETY**" page preceding the Table of Contents. Follow all **NOTES**, **CAUTIONS** and **WARNINGS** to ensure personal safety and prevent damage to the instrument.

Product Support

EADS North America Defense Test and Services, Inc. has a complete Service and Parts Department. If you need technical assistance or should it be necessary to return your product for repair or calibration, call 1-800-722-3262. If parts are required to repair the product at your facility, call 1-949-859-8999 and ask for the Parts Department.

When sending your instrument in for repair, complete the form in the back of this manual.

For worldwide support and the office closest to your facility, refer to the website for the most complete information <http://www.eads-nadefense.com>.

Pin Configuration

The following diagram examines the pin configuration.

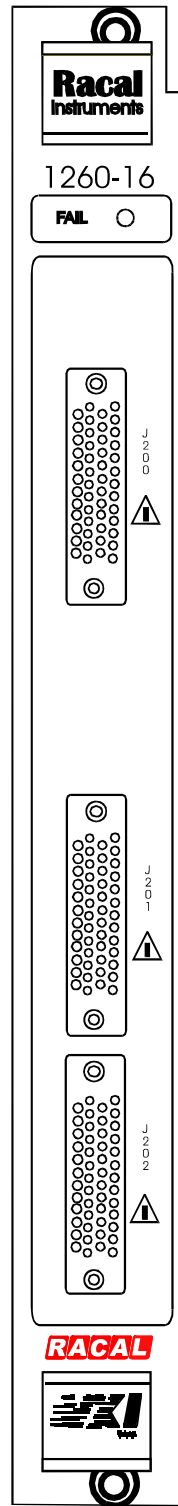

Figure 1-2, 1260-16 Pin Configuration

INSTALLATION INSTRUCTIONS

Unpacking and Inspection



1. Remove the 1260-16 module and inspect it for damage. If any damage is apparent, inform the carrier immediately. Retain shipping carton and packing material for the carrier's inspection.
2. Verify that the pieces in the package you received contain the correct 1260-16 module option and the 1260-16 Users Manual. Notify EADS North America Defense Test and Services, Inc. if the module appears damaged in any way. Do not attempt to install a damaged module into a VXI chassis.
3. The 1260-16 module is shipped in an anti-static bag to prevent electrostatic damage to the module. Do not remove the module from the anti-static bag unless it is in a static-controlled area.

Reshipment Instructions

1. Use the original packing when returning the switching module to EADS North America Defense Test and Services, Inc. for calibration or servicing. The original shipping carton and the instrument's plastic foam will provide the necessary support for safe reshipment.
2. If the original packing material is unavailable, wrap the switching module in an ESD Shielding bag and use plastic spray foam to surround and protect the instrument.
3. Reship in either the original or a new shipping carton.

Option 01 Installation

Installation of the Option 01 into the 1260-16 is described in the Installation section of the 1260 Series VXI Switching Cards Manual (P/N 980673-999).

Module Installation

Installation of the 1260-16 Switching Module into a VXIbus mainframe, including the setting of DIP switches, is described in the Installation section of the 1260 Series VXI Switching Cards Manual (P/N 980673-999). The ID byte DIP switches, SW1-5 and SW1-6, should be set to OFF.

MODULE SPECIFIC SYNTAX

1260-16 Module Specific Syntax

The module specific syntax for the 1260-16 is required in the use of the OPEN and CLOSE commands. It will also appear in the data output by the Master in response to the PDATAOUT and PSETUP commands.

Syntax

The Module Specific Syntax for the 1260-16 module is as follows:

<module address>.<channel>

where <module address> is the switch card address.

<channel> is the channel number to be switched; the range of values for <channel> is 00 to 39.

CLOSE and OPEN Command

Example:

For switch card address 9; channel 2

CLOSE 9.02

OPEN 9.02

Note that channels remain closed until opened by an OPEN command, RESET command, VXI hand or soft reset, or power-off.

NOTE:

The <module address> used here is not the VXIbus defined logical address of the 1260 Master. It is particular to the 1260 Series, and describes the switching module in relation to the Master. This address corresponds to the binary value of the switch setting of SW1 on the module PCB.

PSETUP Command

The PSETUP command causes the specified module setup to be displayed as a response. The syntax used is:

```
PSETUP <module address>[;<module address>][;<module address>].....
```

where <module address> is the address.

The responses to the PSETUP command for the 1260-16 Power Switching Module are as follows:

```
<module address>.1260-16 40 CHANNEL SPDT 5 AMP  
RELAY MODULE
```

```
<module address>.BBM
```

```
<module address>.END
```

The response to the PSETUP command begins with a header on the first line. The header describes the model number. The next line designates the setup mode for scanning, which, by default, is Break-Before-Make (BBM). The last line containing the "END" characters denotes no more information to report.

PDATAOUT Command

The PDATAOUT command causes the specified module to transmit the state of the CLOSED relays (within the switching module) to the 1260 Controller. The syntax used is:

```
PDATAOUT <module address>[.<module address>][;<module address>].....
```

The responses to the PDATAOUT command are as follows:

```
<module address>.1260-16 40 CHANNEL SPDT 5 AMP  
RELAY MODULE
```

```
<module address>.<channel>[,<channel>][,<channel>].....
```

```
<module address>.END
```

The response to the PDATAOUT command consists of a header on the first line, as with the PSETUP response. The next line details the channels currently closed on the module, and is blank when no channels are closed. Again, the last line is denoted by the "END" string of characters.

MODULE CONFIGURATION

General

The 1260-16 Power Switching module provides 40 independent channels of SPDT switching. Each channel functions independently, with all paths accessible through the front panel connectors. Every channel features mounting holes on the printed circuit board to allow for the addition of one series and two shunt elements. This permits components, such as fuses and arc suppressers (for contact protection), or resistors and capacitors (for filter circuits) to be installed. The circuit board also provides mounting holes for jumpers to allow up to eight common channels to be multiplexed. This can save external wiring when several channels are switched to the common channel. The module permits switching currents of up to 5 amps at 30 volts DC or 250 volts RMS per channel.

CAUTION:

Open unit at an ESD static safe work station.

A total of 150 pins are accessible through the front panel connectors, 18 of which are not used. Each channel is assigned 3 pins: COM, NO and NC, as shown in **Figure 4-1**.

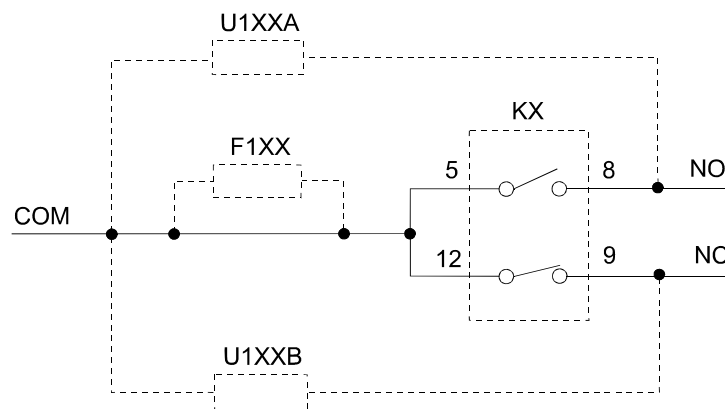

Figure 4-1, 1260-16 Relay Diagram

The corresponding pin assignments of the 3 pins for each channel are shown in **Table 4-1**.

Connector Pin Configuration

Refer to Figure 4-2 for pin configurations of the front panel connectors J200 to J202. J200 to J202 are Part Number 601856-050. The mating connectors are Part Number 601855-050, and mating pins are Part Number 601857.

Table 4-1, 1260-16 "COM, NO and NC" Assignments

CHANNEL NO.	COM	NO	NC
0	J200-a	J200-c	J200-Y
1	J200-b	J200-d	J200-Z
2	J200-U	J200-W	J200-S
3	J200-V	J200-X	J200-T
4	J200-M	J200-P	J200-K
5	J200-N	J200-R	J200-L
6	J200-E	J200-H	J200-C
7	J200-F	J200-J	J200-D
8	J201-E	J201-H	J201-C
9	J201-F	J201-J	J201-D
10	J200-BB	J200-DD	J200-z
11	J200-CC	J200-EE	J200-AA
12	J200-v	J200-x	J200-t
13	J200-w	J200-y	J200-u
14	J200-n	J200-r	J200-k
15	J200-p	J200-s	J200-m
16	J201-r	J201-t	J201-n
17	J201-s	J201-u	J201-p
18	J201-h	J201-k	J201-e
19	J201-j	J201-m	J201-f
20	J201-a	J201-c	J201-Y
21	J201-b	J201-d	J201-Z
22	J201-U	J201-W	J201-S
23	J201-V	J201-X	J201-T
24	J202-U	J202-W	J202-S
25	J202-V	J202-X	J202-T
26	J202-M	J202-P	J202-K
27	J202-N	J202-R	J202-L
28	J202-E	J202-H	J202-C
29	J202-F	J202-J	J202-D
30	J201-BB	J201-DD	J201-z
31	J201-CC	J201-EE	J201-AA
32	J202-BB	J202-DD	J202-z
33	J202-CC	J202-EE	J202-AA
34	J202-v	J202-x	J202-t
35	J202-w	J202-y	J202-u
36	J202-n	J202-r	J202-k
37	J202-p	J202-s	J202-m
38	J202-e	J202-h	J202-c
39	J202-f	J202-j	J202-d

Table 4-1, 1260-16 "COM, NO and NC" Assignments (continued)

Multiplexer Channel Assignments

Multiplexer Channel	Pin
COM0_7	J200-A
COM8_15	J200-h
COM16_23	J201-x
COM24_31	J201-P
COM32_39	J202-Y

Chassis Ground

J200-B	J200-HH
J201-B	J201-HH
J202-B	J202-HH

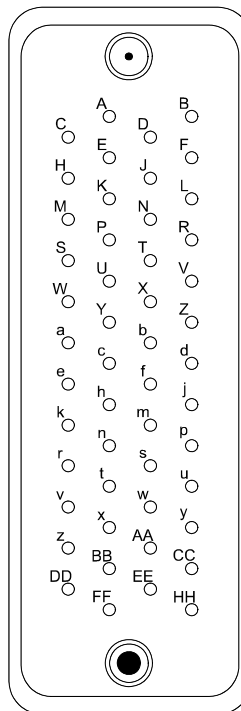

Figure 4-2, 1260-16 J200-J202 Pin Configuration

Figure 4-3 shows a 1260-16 channel with one series and two shunt elements associated with each channel. The series elements are designated F100 to F139, while the shunt elements are designated U100A/B to U139A/B. To allow immediate use of the module, a trace is provided on the printed circuit board (component side) in all positions for F100 to F139. No components are installed at U100A/B to U139A/B.

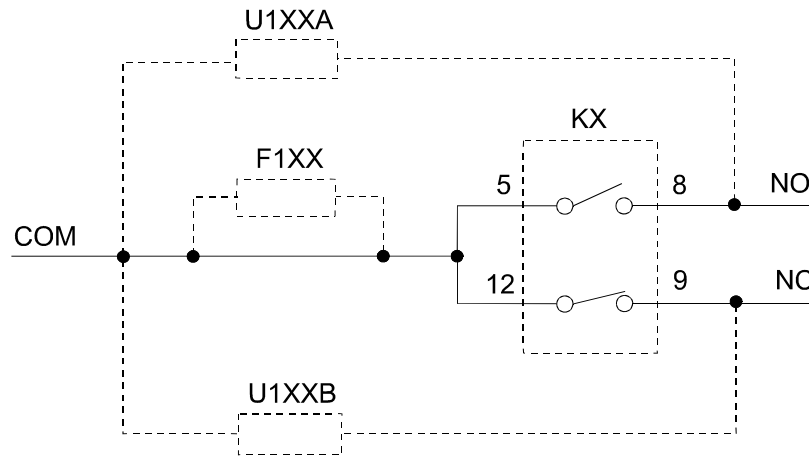

Figure 4-3, 1260-16 Channel

Series elements are installed at F100 to F139 positions. The "F" position has a numerical assignment that is one hundred and one (101) higher than the channel number. For example, the series elements associated with CH 8 will have the designation F109. At shipment, the module is provided with traces on the printed circuit board (component side) at the "F" positions. Installation of a series element will first require the removal of the trace at the location of interest. Only qualified personnel should attempt this procedure. Each trace is located above the channel relay. (See **Figure 4-4**.) The trace can be seen to narrow down for 0.10 inches. This 0.10-inch portion of the trace should be removed using a suitable tool such as a scalpel.

ESD CAUTION:

Open unit at an ESD static safe workstation.

A fuse may be used in the "F" positions to protect the relay and associated connections. An example of a suitable fuse is the Littlefuse Pico II 250V (part number 263 005). Note that the fuse selected must be rated to the maximum voltage applied.

To install shunt elements at a particular channel, locate the "U" position which has a numerical assignment that is one hundred and one (101) higher than the channel number. For example, the shunt elements associated with CH 19 will have the designations U120A and U120B. Note that each channel has two shunt elements: element "A" is connected between the NO channel and COM while element "B" is connected between the NC channel and COM

EXAMPLE: CHANNEL 7

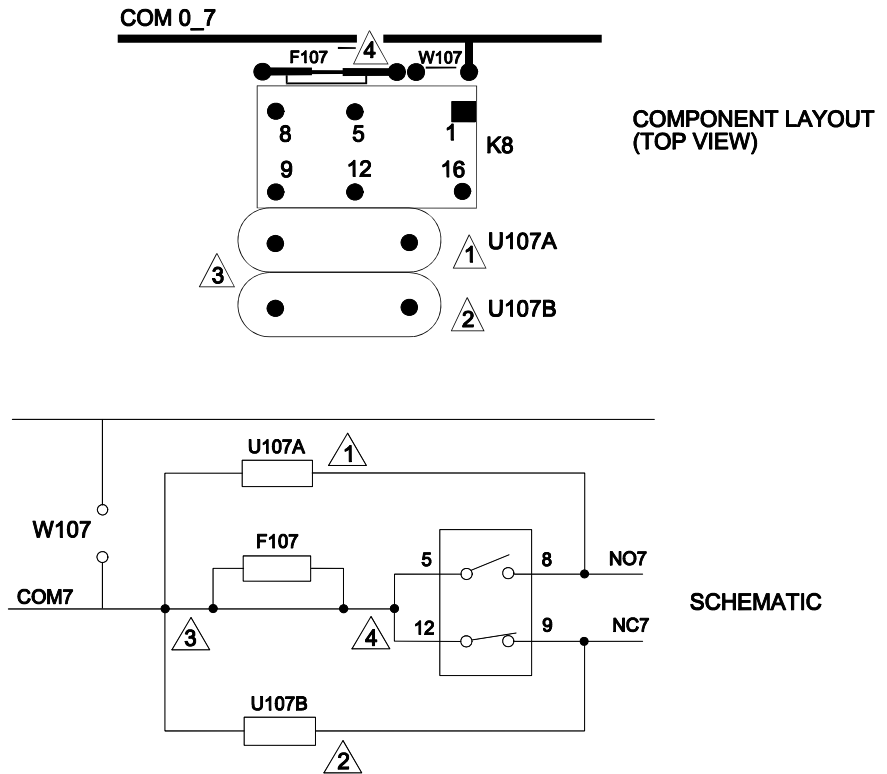

Figure 4-4, 1260-16 Components Per Channel

For the shunt elements, metal oxide varistors (MOVs) may be used to suppress voltage spikes. An example of a suitable MOV is Phillips-type 2322 592 A3006 for DC operation or Phillips-type 2322 592 G2516 for AC operation. The exact component selection will depend on the application.

Figure 4-4 summarizes the components associated with each channel and illustrates the trace to be cut. It also shows how the series and shunt elements are connected to the relay (refer to the numbered triangles and their respective positions). This may be useful when the elements being installed have associated polarities.

Multiplexers can be implemented by installing jumpers at the mounting holes above each relay. Referring to **Figure 4-5**, mounting holes are provided between the COM side of each relay and a single trace which runs alongside each row of 8 relays. This arrangement can be used to implement an 8 x 1 multiplexer, using the 8 adjacent relays. For example, to implement an 8 x 1 multiplexer using K1 to K8, use jumpers to connect W100 to W107 (see **Figure 4-5**). K1 to K8 now composes a single wire, 8 x 1 multiplexer with COM0_7 as the common. Typically, for each relay, the NC path would be unconnected and the NO path used as the branch for the multiplexer. The other four rows of eight relays can be configured in the same manner to provide a total of five 8 x 1 multiplexers. The pin assignment of the common pairs is shown on Table 4-1.

The relays used on the 1260-16 are designed to switch up to 5 amps at 30 volts DC or 250 volts RMS. The relay contacts are made of silver alloy and have a "gold flash" coating to prevent oxidation during storage. With frequent switching operation above 2 amps, it is normal for the gold flash to be removed from the contacts. Without the gold flash, oxidation may build up on the contacts if the relay is not operated for some time. On the next operation with currents above approximately 0.5 amps, the oxidation will be removed immediately. However, if the unit is operated with lower currents, the oxidation may not be removed and an open circuit condition may prevail. This scenario is typical with all brands of relays rated at this current. EADS North America Defense Test and Services, Inc. recommends that the customer designate each 1260-16 module purchased as either a low current switch (less than 1 amp) or a high current switch (greater than 1 amp).

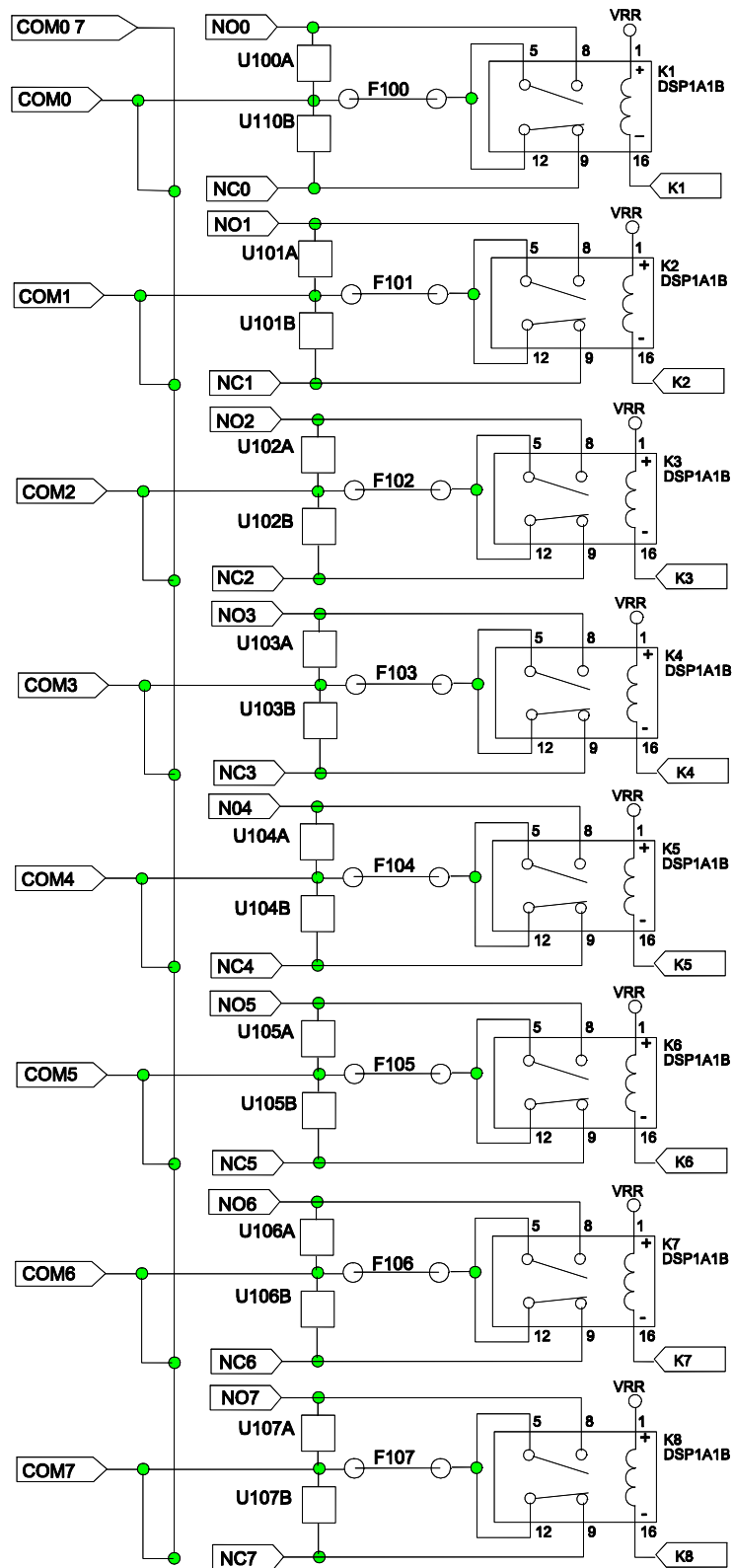

Figure 4-5, 1260-16 Jumper Locations

This page was left intentionally blank.

Chapter 5

OPTIONAL HARNESS ASSEMBLIES

The following harness assemblies are used to connect 1260-16 to Freedom Series Test Receiver Interfaces.

Each harness documentation consists of an assembly drawing, parts list, system wire list and wire list.

407435 Virginia Panel, Inc. Series VP90
Interface Harness

407436 TTI Testron, Inc. Interface Harness

For more information on Racal Instruments™ complete line of Test Receivers Interface solution, contact your Sales Representative.

This page was left intentionally blank.

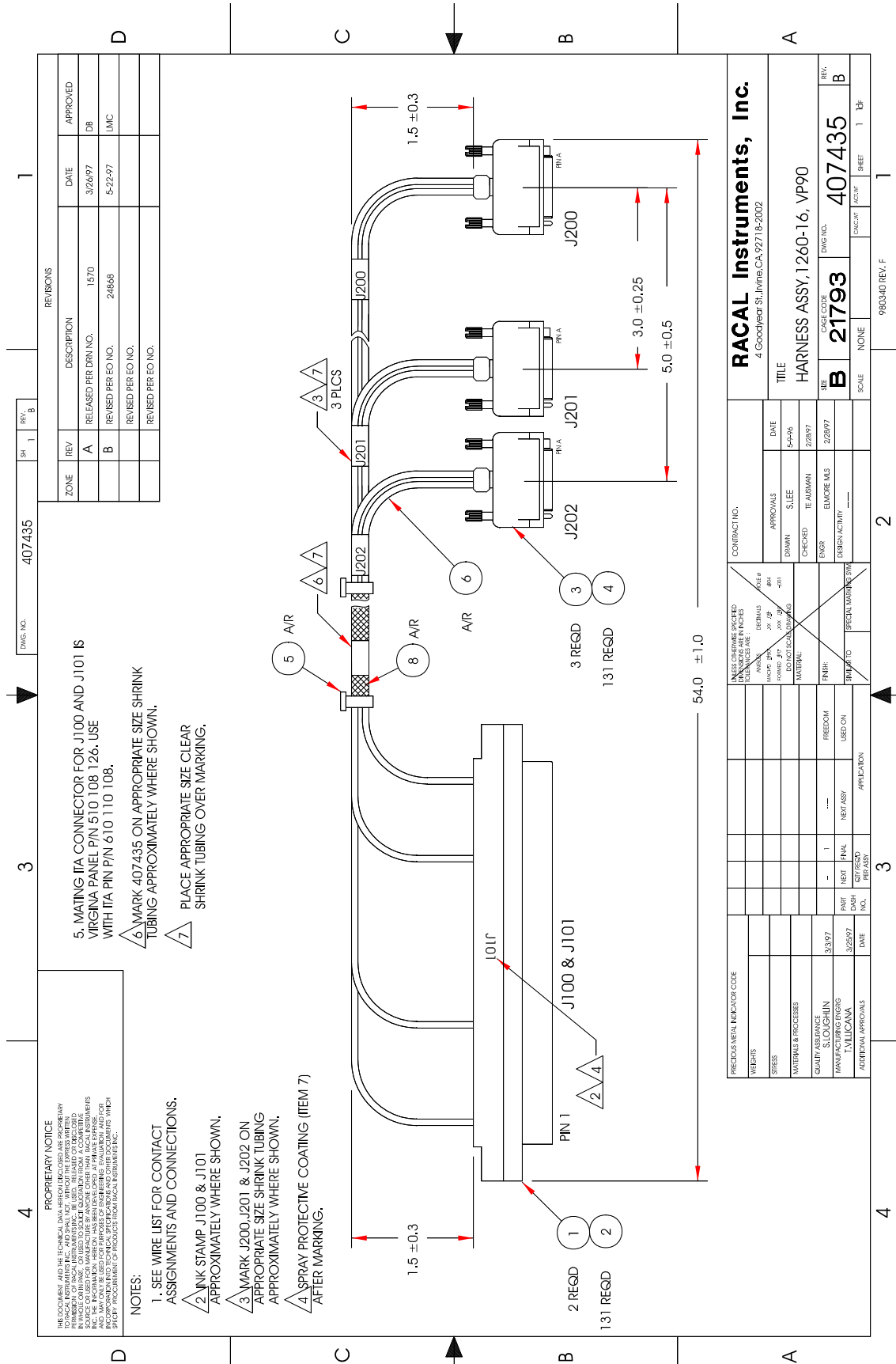

ENGINEERING PARTS LIST

ITEM	REV	PART NO.	DESCRIPTION	QTY	REFERENCE
1		602201-003	CON-RCV-PLG096.---D	2	J100,J101
2		602201-906	CONTACT, SIGNAL, 22AW0, VP90	131	(J100,J101)
3		601855-050	CON-CAB-PLG50CP.	3	J200-J202
4		602092-001	CONT, SGMC MALE CRIMP	131	(J200-J202)
5		610777	TIE-CA-LKG-.062-.075	A/R	
6		523999	WRTEF, STR22G-999	A/R	
7		910541	POLYURETHANE CONF. COAT	A/R	
8		GRP-110-1/2	SLEEVING,BRAIDED POLY,1/2	A/R	

RACAL Instruments™, Inc., 4 Goodyear St., Irvine, CA 92718				
DOCUMENT TITLE	SIZE	CODE NO	DOCUMENT NO	REV
HARNESS ASSEMBLY, 1260-16, VP90	A	21793	407435	B
	DRN		SHEET 2 Of 11	

ENGINEERING WIRE LIST

WIRE	FROM	TO	TYPE	PART #	WIRE LEN	REFERENCE
	BLK AA (J100)	Uxx-SLOT yy (J200,J20 1)	CABLE	407435		SYSTEM WIRE LIST
	BLK AA (J101)	Uxx-SLOT yy (J201,J202)	CABLE	407435		

This system wirelist serves as a template for incorporating this harness assembly into the overall system wirelist. It does not in any way affect the fabrication of this harness assembly.

RACAL Instruments™, Inc., 4 Goodyear St., Irvine, CA 92718				
DOCUMENT TITLE	SIZE	CODE NO	DOCUMENT NO	REV
HARNESS ASSEMBLY, 1260-16, VP90	A	21793	407435	B
	DRN		SHEET	3 Of 11

ENGINEERING WIRE LIST

WIRE	FROM	TO	TYPE	PART #	WIRE LEN	REFERENCE
1	3100-1 602201-906	3200-A 602092-001	22AW0 WHT	523999	54"	COM0_7
2	3100-2 602201-906	J200-Y 602092-001	22AWG WRT	523999	54"	NC0
3	J100-3 602201-906	3200-Z 602092-001	22AWG WHT	523999	54"	NC1
4	3100-4					NO CONNECTION
5	3100-5 602201-906	3200-S 602092-001	22AWG WHT	523999	54"	NC2
6	3100-6 602201-906	3200-T 602092-001	22AWG WHT	523999	54"	NC3
7	3100-7					NO CONNECTION
8	3100-8 602201-906	3200-K 602092-001	22AW0 WRT	523999	54"	NC4
9	3100-9 602201-906	J200-L 602092-001	22AW0 WHT	523999	54"	NC5
10	3100-10					NO CONNECTION
11	3100-11 602201-906	3200-C 602092-001	22AWG WHT	523999	54"	NC6
12	3100-12 602201-906	3200-D 602092-001	22AWG WHT	523999	54"	NC7
13	3100-13 602201-906	3200-h 602092-001	22AWG WHT	523999	54"	COM8_15
14	3100-14 602201-906	3201-C 602092-001	22AWG WHT	523999	54"	NC8
15	3100-15 602201-906	J201-D 602092-001	22AW0 WRT	523999	54"	NC9
16	3100-16					NO CONNECTION
17	3100-17 602201-906	J200-z 602092-001	22AW6 WHT	523999	54"	NC10
18	3100-18 602201-906	3200-AA 602092-001	22AW0 WHT	523999	54"	NC11
19	3100-19					NO CONNECTION
20	3100-20 602201-906	J200-t 602092-001	22AWG WRT	523999	54"	NC12
21	3100-21 602201-906	3200-u 602092-001	22AWG WRT	523999	54"	NC13
22	3100-22					NO CONNECTION
23	3100-23 602201-906	3200-k 602092-001	22AWG WHT	523999	54"	NC14
24	3100-24 602201-906	3200-m 602092-001	22AW0 WHT	523999	54"	NC15
25	3100-25 602201-906	3201-x 602092-001	22AWG WHT	523999	54"	COM16_23

RACAL Instruments™, Inc., 4 Goodyear St., Irvine, CA 92718

DOCUMENT TITLE	SIZE	CODE NO	DOCUMENT NO	REV
HARNESS ASSEMBLY, 1260-16, VP90	A	21793	407435	B
	DRN		SHEET	4 Of 11

ENGINEERING WIRE LIST

WIRE	FROM	TO	TYPE	PART #	WIRE LEN	REFERENCE
26	3100-26 602201-906	3201-n 602092-001	22AWG WHT	523999	54"	NC16
27	3100-27 602201-906	3201-p 602092-001	22AW6 WHT	523999	54"	NC17
28	3100-28					NO CONNECTION
29	3100-29 602201-906	3201-c 602092-001	22AW0 WHT	523999	54"	NC18
30	3100-30 602201-906	3201-f 602092-001	22AW0 WHT	523999	54"	NC19
31	1100-31					NO CONNECTION
32	3100-32					NO CONNECTION
33	3100-33					NO CONNECTION
34	310034 602201-906	3200-a 602092-001	22AWG WHT	523999	54"	COM0
35	3100-35 602201-906	3200-b 602092-001	22AW0 WHT	523999	54"	COM1
36	310036					NO CONNECTION
37	3100-37 602201-906	3200-U 602092-001	22AWG WHT	523999	54"	COM2
38	3100-38 602201-906	3200-V 602092-001	22AW6 WHT	523999	54"	COM3
39	3100-39					NO CONNECTION
40	3100-40 602201-906	3200-M 602092-001	22AW0 WHT	523999	54"	COM4
41	3100-41 602201-906	3200-N 602092-001	22AW0 WHT	523999	54"	COM5
42	3100-42					NO CONNECTION
43	3100-43 602201-906	3200-E 602092-001	22AW0 WHT	523999	54"	COM6
44	310044 602201-906	3200-F 602092-001	22AW0 WHT	523999	54"	COM7
45	3100-45					NO CONNECTION
46	310046 602201-906	3201-E 602092-001	22AW0 WHT	523999	54"	COM8
47	3100-47 602201-906	3201-F 602092-001	22AW0 WRT	523999	54"	COM9
48	3100-48					NO CONNECTION
49	3100-49 602201-906	3200-BB 602092-001	22AWG WHT	523999	54"	COM10
50	3100-50 602201-906	3200-CC 602092-001		523999	54"	COM11

RACAL Instruments™, Inc., 4 Goodyear St., Irvine, CA 92718

DOCUMENT TITLE	SIZE	CODE NO	DOCUMENT NO	REV
HARNESS ASSEMBLY, 1260-16, VP90	A	21793	407435	B
	DRN		SHEET	5 Of 11

ENGINEERING WIRE LIST

WIRE	FROM	TO	TYPE	PART #	WJRE LEN	REFERENCE
51	3100-51					NO CONNECTION
52	3130-52 602201-906	3200-v 602092-001	22AW0 WHT	523999	54"	COM12
53	3100-53 602201-906	3200w 602092-001	22AW0 WHT	523999	54"	COM13
54	3100-54					NO CONNECTION
55	3100-55 602201-906	3200-n 602092-001	22AW0 WHT	523999	54"	COM14
56	3100-56 602201-906	3200-p 602092-001	22AWG WHT	523999	54"	COM15
57	3100-57					NO CONNECTION
58	3100-58 602201-906	3201-r 602092-001	22AW0 WHT	523999	54"	COM16
59	3100-59 602201-906	3201-s 602092-001	22AWG WHT	523999	54"	COM17
60	3100-60					NO CONNECTION
61	3100-61 602201-906	3201-h 602092-001	22AWG WHT	523999	54"	COM18
62	3100-62 602201-906	3201-j 602092-001	22AWG WHT	523999	54"	COM19
63	3100-63					NO CONNECTION
64	3100-64					NO CONNECTION
65	310065 602201-906	3200-B 602092-001	22AW0 WHT	523999	54"	CHASSIS GND
66	3100-66 602201-906	3200-c 602092-001	22AWG WHT	523999	54"	NO0
67	3100-67 602201-906	3200-d 602092-001	22AWG WHT	523999	54"	NO1
68	310068					NO CONNECTION
69	3100-69 602201-906	3200W 602092-001	22AWG WHT	523999	54"	NO2
70	3100-70 602201-906	3200-X 602092-001	22AW0 WHT	523999	54"	NO3
71	3100-71					NO CONNECTION
72	3100-72 602201-906	3200-P 602092-001	22AWG WHT	523999	54"	NO4
73	3100-73 602201-906	3200-R 602092-001	22AWG WHT	523999	54"	NO5
74	3100-74					NO CONNECTION
75	3100-75 602201-906	3200-H 602092-001	22AW6 WHT	523999	54"	NO6

RACAL Instruments™ Inc., 4 Goodyear St., Irvine, CA 92718

DOCUMENT TITLE	SIZE	CODE NO	DOCUMENT NO	REV
HARNESS ASSEMBLY, 1260-16, VP90	A	21793	407435	B
DRN			SHEET 6 Of 11	

ENGINEERING WIRE LIST

WIRE	FROM	TO	TYPE	PART #	WIRE LEN	REFERENCE
76	3100-76 602201-906	3200-J 602092-001	22AWG WHT	523999	54"	NO7
77	3100-77					NO CONNECTION
78	3100-78 602201-906	3201-H 602092-001	22AW0 WHT	523999	54"	NO8
79	3100-79 602201-906	3201-J 602092-001	22AW0 WHT	523999	54"	NO9
80	3100-80					NO CONNECTION
81	1100-81 602201-906	J200-DD 602092-001	22AW0 WHT	523999	54"	NO10
82	3100-82 602201-906	3200-EE 602092-001	22AWG WHT	523999	54"	NO11
83	1100-83					NO CONNECTION
84	3100-84 602201-906	3200-x 602092-001	22AW0 WHT	523999	54"	NO12
85	3100-85 602201-906	J200-y 602092-001	22AWG WHT	523999	54"	NO13
86	31()()-86					NO CONNECTION
87	3100-87 602201-906	3200-r 602092-001	22AWG WHT	523999	54"	NO14
88	3100-88 602201-906	3200-s 602092-001	22AW0 WHT	523999	54"	NO15
89	3100-89					NO CONNECTION
90	3100-90 602201-906	3201-t 602092-001	22AW0 WHT	523999	54"	NO16
91	3100-91 602201-906	3201-u 602092-001	22AW0 WHT	523999	54"	NO17
92	3100-92					NO CONNECTION
93	3100-93 602201-906	3201-k 602092-001	22AW0 WHT	523999	54"	NO18
94	3100-94 602201-906	3201-rn 602092-001	22AWG WHT	523999	54"	NO19
95	3100-95					NO CONNECTION
96	3100-96 602201-906	J200-HH 602092-001	22AWG WHT	523999	54"	CHASSIS GND
97	NOT USED					
98	NOT USED					
99	NOT USED					
100	NOT USED					

RACAL Instruments™ Inc., 4 Goodyear St., Irvine, CA 92718

DOCUMENT TITLE	SIZE	CODE NO	DOCUMENT NO	REV
HARNESS ASSEMBLY, 1260-16, VP90	A	21793	407435	B
	DRN		SHEET 7 Of 11	

ENGINEERING WIRE LIST

WIRE	FROM	TO	TYPE	PART #	WIRE LEN	REFERENCE
101	3101-1 602201-906	3201-B 602092-001	22AWG WHT	523999	54"	CHASSIS GND
102	3101-2 602201-906	J201-Y 602092-001	22AWG WHT	523999	54"	NC20
103	3101-3 602201-906	3201-Z 602092-001	22AWG WHT	523999	54"	NC21
104	3101-4					NO CONNECTION
105	3101-5 602201-906	3201-S 602092-001	22AW0 WHT	523999	54"	NC22
106	3101-6 602201-906	3201-T 602092-001	22AW0 WHT	523999	54"	NC23
107	3101-7 602201-906	3201-P 602092-001	22AWG WHT	523999	54"	COM24_31
108	3101-8 602201-906	3202-S 602092-001	22AW0 WHT	523999	54"	NC24
109	3101-9 602201-906	3202-T 602092-001	22AWG WHT	523999	54"	NC25
110	3101-10					NO CONNECTION
111	3101-11 602201-906	3202-K 602092-001	22AW6 WHT	523999	54"	NC26
112	3101-12 602201-906	3202-L 602092-001	22AW0 WHT	523999	54"	NC27
113	3101-13					NO CONNECTION
114	3101-14 602201-906	3202-C 602092-001	22AW0 WHT	523999	54"	NC28
115	3101-15 602201-906	3202-D 602092-001	22AW6 WHT	523999	54"	NC29
116	3101-16					NO CONNECTION
117	3101-17 602201-906	3201-z 602092-001	22AWG WHT	523999	54"	NC30
118	3101-18 602201-906	3202-AA 602092-001	22AW0 WHT	523999	54"	NC31
119	3101-19					NO CONNECTION
120	3101-20 602201-906	3202-z 602092-001	22AW0 WHT	523999	54"	NC32
121	3101-21 602201-906	3202-AA 602092-001	22AW6 WHT	523999	54"	NC33
122	3101-22					NO CONNECTION
123	3101-23 602201-906	J202-t 602092-001	22AWG WHT	523999	54"	NC34
124	J101-24 602201-906	3202-u 602092-001	22AWG WHT	523999	54"	NC35
125	3101-25					NO CONNECTION

RACAL Instruments™ Inc., 4 Goodyear St., Irvine, CA 92718

DOCUMENT TITLE	SIZE	CODE NO	DOCUMENT NO	REV
HARNESS ASSEMBLY, 1260-16, VP90	A	21793	407435	B
DRN			SHEET 8 Of 11	

ENGINEERING WIRE LIST

WIRE	FROM	TO	TYPE	PART #	WIRE LEN	REFERENCE
126	3101-26 602201-906	3202-k 602092-001	22AW0 WHT	523999	54"	NC36
127	3101-27 602201-906	3202-rn 602092-001	22AW0 WHT	523999	54"	NC37
128	3101-28					NO CONNECTION
129	3101-29 602201-906	3202-c 602092-001	22AW6 WHT	523999	54"	NC38
130	3101-30 602201-906	J202-d 602092-001	22AWG WHT	523999	54"	NC39
131	3101-31					NO CONNECTION
132	3101-32 ~02201-906	J201-HH 602092-001	22AW6 WHT	523999	54"	CHASSIS ONE
133	3101-33					NO CONNECTION
134	3101-34 602201-906	3201-a 602092-001	22AW0 WHT	523999	54"	COM20
135	3101-35 602201-906	3201-b 602092-001	22AW0 WHT	523999	54"	COM21
136	3101-36					NO CONNECTION
137	3101-37 602201-906	3201-U 602092-001	22AWG WHT	523999	54"	COM22
138	3101-38 602201-906	3201-V 602092-001	22AW0 WHT	523999	54"	COM23
139	3101-39					NO CONNECTION
140	3101-40 602201-906	3202-U 602092-001	22AW0 WHT	523999	54"	COM24
141	3101-41 602201-906	3202-V 602092-001	22AW6 WHT	523999	54"	COM25
142	3101-42					NO CONNECTION
143	3101-43 602201-906	3202-M 602092-001	22AWG WHT	523999	54"	COM26
144	3101-44 602201-906	3202-N 602092-001	22AW0 WHT	523999	54"	COM27
145	3101-45					NO CONNECTION
146	3101-46 602201-906	3202-E 602092-001	22AW6 WHT	523999	54"	COM28
147	3101-47 602201-906	3202-F 602092-001	22AW6 WHT	523999	54"	COM29
148	3101-48					NO CONNECTION
149	3101-49 602201-906	J201-BB 602092-001	22AW0 WHT	523999	54"	COM30
150	3101-50 602201-906	3201-CC 602092-001	22AW6 WHT	523999	54"	COM31
RACAL Instruments™ Inc., 4 Goodyear St., Irvine, CA 92718						
DOCUMENT TITLE			SIZE	CODE NO	DOCUMENT NO	REV
HARNESS ASSEMBLY, 1260-16, VP90			A	21793	407435	B
DRN					SHEET	9 Of 11

ENGINEERING WIRE LIST

WIRE	FROM	TO	TYPE	PART #	WIRE LEN	REFERENCE
151	3101-51 602201-906	3202-Y 602092-001	22AW0 WHT	523999	54"	COM32_39
152	3101-52 602201-906	J202-BB 602092-001	22AWG WHT	523999	54"	COM32
153	3101-53 602201-906	3202-CC 602092-001	22AWG WHT	523999	54"	COM33
154	3101-54					NO CONNECTION
155	3101-55 602201-906	3202-v 602092-001	22AWG WHT	523999	54"	COM34
156	3101-56 602201-906	J202-w 602092-001	22AW0 WHT	523999	54"	COM35
157	3101-57					NO CONNECTION
158	3101-58 602201-906	3202-n 602092-001	22AW0 WHT	523999	54"	COM36
159	3101-59 602201-906	3202-p 602092-001	22AW0 WHT	523999	54"	COM37
160	3101-60					NO CONNECTION
161	3101-61 602201-906	3202-e 602092-001	22AWG WHT	523999	54"	COM38
162	3101-62 602201-906	3202-f 602092-001	22AW0 WHT	523999	54"	COM39
163	3101-63					NO CONNECTION
164	3101-64					NO CONNECTION
165	3101-65 602201-906	3202-B 602092-001	22AWG WHT	523999	54"	CHASSIS GND
166	3101-66 602201-906	3201-c 602092-001	22AWG WHT	523999	54"	NO20
167	3101-67 602201-906	J201-d 602092-001	22AWG WHT	523999	54"	NO21
168	3101-68					NO CONNECTION
169	3101-69 602201-906	3201-W 602092-001	22AWG WHT	523999	54"	NO22
170	3101-70 602201-906	3201-X 602092-001	22AW6 WHT	523999	54"	NO23
171	3101-71					NO CONNECTION
172	3101-72 602201-906	3202-W 602092-001	22AW0 WHT	523999	54"	NO24
173	3101-73 602201-906	3202-X 602092-001	22AW0 WHT	523999	54"	NO25
174	3101-74					NO CONNECTION
175	3101-75 602201-906	3202-P 602092-001	22AW6 WHT	523999	54"	NO26
RACAL Instruments™ Inc., 4 Goodyear St., Irvine, CA 92718						
DOCUMENT TITLE			SIZE	CODE NO	DOCUMENT NO	REV
HARNESS ASSEMBLY, 1260-16, VP90			A	21793	407435	B
			DRN		SHEET	10 Of 11

ENGINEERING WIRE LIST

WIRE	FROM	TO	TYPE	PART #	WIRE LEN	REFERENCE
176	3101-76 602201-906	J202-R 602092-001	22AW6 WHT	523999	54"	NO27
177	3101-77					NO CONNECTION
178	3101-78 602201-906	3202-H 602092-001	22AW0 WHT	523999	54"	NO28
179	3101-89 602201-906	3202-3 602092-001	22AW6 WHT	523999	54"	NO29
180	3101-80					NO CONNECTION
181	3101-81 602201-906	J201-DD 602092-001	22AWG WHT	523999	54"	NO30
182	3101-82 602201-906	J201-EE 602092-001	22AWG WHT	523999	54"	NO31
183	3101-83					NO CONNECTION
184	3101-84 602201-906	J202-DD 602092-001	22AW6 WHT	523999	54"	NO32
185	3101-85 602201-906	3202-EE 602092-001	22AW0 WHT	523999	54"	NO33
186	3101-86					NO CONNECTION
187	3101-87 602201-906	J202-x 602092-001	22AWG WHT	523999	54"	NO34
188	3101-88 602201-906	3202-y 602092-001	22AWG WHT	523999	54"	NO35
189	3101-99					NO CONNECTION
190	3101-90 602201-906	3202-r 602092-001	22AWG WHT	523999	54"	NO36
191	3101-91 602201-906	3202-s 602092-001	22AW0 WHT	523999	54"	NO37
192	3101-92					NO CONNECTION
193	3101-93 602201-906	3202-h 602092-001	22AW6 WHT	523999	54"	NO38
194	3101-94 602201-906	3202-j 602092-001	22AWG WHT	523999	54"	NO39
195	3101-95					NO CONNECTION
196	3101-96 602201-906	J202-HH 602092-001	22AW0 WHT	523999	54"	CHASSIS GND

RACAL Instruments™ Inc., 4 Goodyear St., Irvine, CA 92718

DOCUMENT TITLE	SIZE	CODE NO	DOCUMENT NO	REV
HARNESS ASSEMBLY, 1260-16, VP90	A	21793	407435	B
	DRN		SHEET	11 Of 11

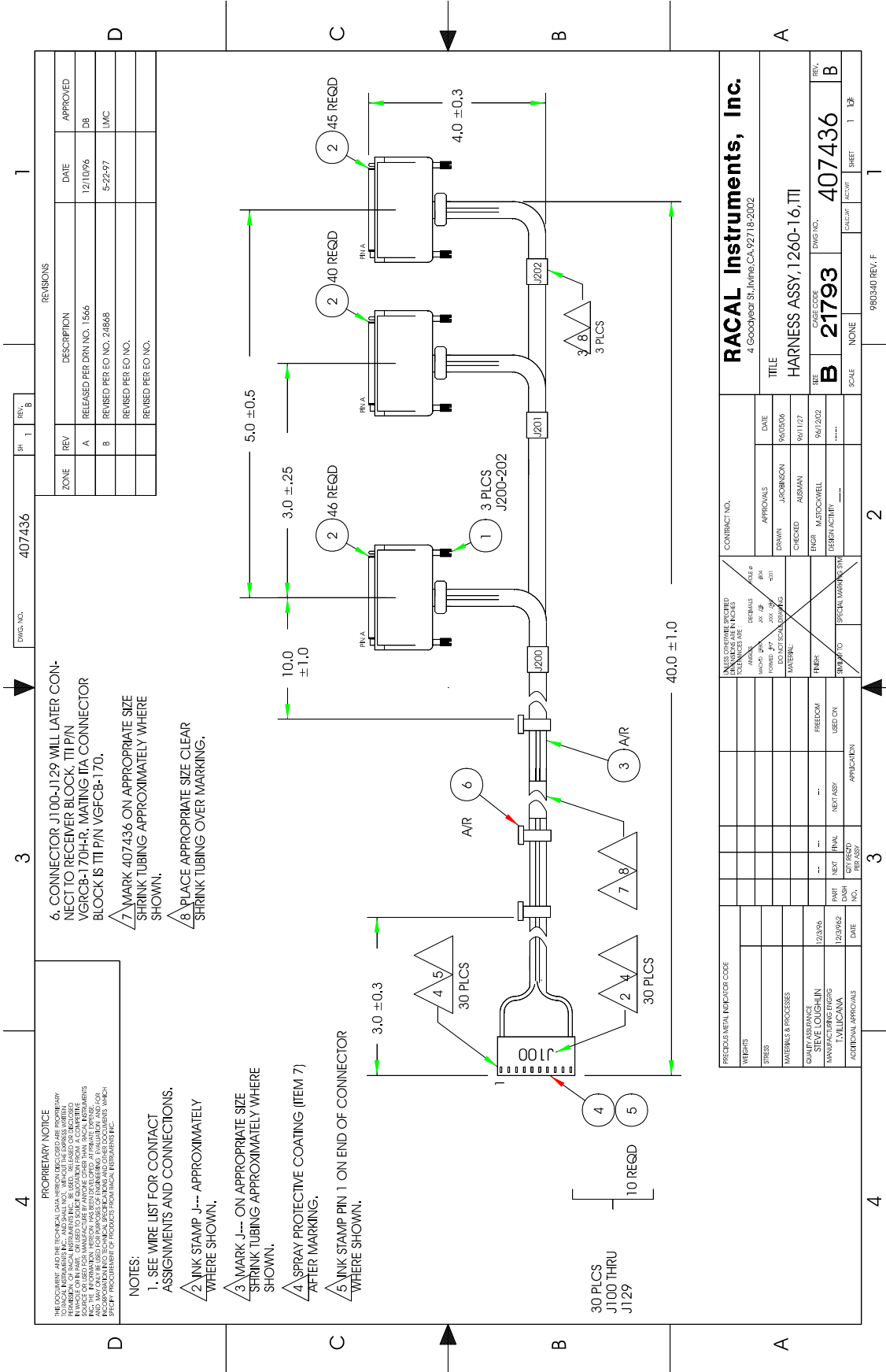

REVISIONS				
ZONE	REV	DESCRIPTION	DATE	APPROVED
A	1	RELEASED PER DRN NO. 15646	12/10/96	DB
B	2	REVISED PER EO NO. 24868	5-22-97	LMC
		REVISED PER EO NO.		
		REVISED PER EO NO.		

6. CONNECTOR J100-J129 WILL LATER CONNECT TO RECEIVER BLOCK, TTI P/N VGRCB-170HR; MATING IFA CONNECTOR BLOCK IS TTI P/N VGFCB-170.

7. MARK 407436 ON APPROPRIATE SIZE SHRINK TUBING APPROXIMATELY WHERE SHOWN.

8. PLACE APPROPRIATE SIZE CLEAR SHRINK TUBING OVER MARKING.

PROPRIETARY NOTICE
 THIS DRAWING AND THE TECHNICAL INFORMATION CONTAINED HEREIN ARE THE PROPERTY OF RACAL INSTRUMENTS, INC. IT IS LOANED TO YOU BY RACAL INSTRUMENTS, INC. FOR YOUR INFORMATION AND USE ONLY. IT IS NOT TO BE REPRODUCED, COPIED, OR TRANSMITTED IN ANY FORM OR BY ANY MEANS, ELECTRONIC OR MECHANICAL, INCLUDING PHOTOCOPYING, RECORDING, OR BY ANY INFORMATION STORAGE AND RETRIEVAL SYSTEM, WITHOUT THE WRITTEN PERMISSION OF RACAL INSTRUMENTS, INC. THIS DRAWING IS THE PROPERTY OF RACAL INSTRUMENTS, INC. AND IS NOT TO BE REPRODUCED, COPIED, OR TRANSMITTED IN ANY FORM OR BY ANY MEANS, ELECTRONIC OR MECHANICAL, INCLUDING PHOTOCOPYING, RECORDING, OR BY ANY INFORMATION STORAGE AND RETRIEVAL SYSTEM, WITHOUT THE WRITTEN PERMISSION OF RACAL INSTRUMENTS, INC.

NOTES:
 1. SEE WIRE LIST FOR CONTACT ASSIGNMENTS AND CONNECTIONS.
 2. INK STAMP J--- APPROXIMATELY WHERE SHOWN.

3. MARK J--- ON APPROPRIATE SIZE SHRINK TUBING APPROXIMATELY WHERE SHOWN.

4. SPRAY PROTECTIVE COATING (ITEM 7) AFTER MARKING.

5. INK STAMP PIN 1 ON END OF CONNECTOR WHERE SHOWN.

PRECISION METAL INDICATOR CODE		CONTRACT NO.	
WEIGHTS		RACAL Instruments, Inc.	
STRESS		4 Goodyear St. Irvine CA, 92718-2002	
MATERIALS & PROCESSES		TITLE	
COATING FINISH		HARNES ASSY, 1260-16, TTI	
MANUFACTURING ENGRS		DRAWN	
DATE		CHECKED	
		ENGR	
		TERMIN ACTIVITY	
		SCALE	
		SHEET	
		REV.	

DATE	DATE
APPROVALS	APPROVALS
DRAWN	DRAWN
CHECKED	CHECKED
ENGR	ENGR
TERMIN ACTIVITY	TERMIN ACTIVITY
SCALE	SCALE
SHEET	SHEET
REV.	REV.

DATE	DATE
APPROVALS	APPROVALS
DRAWN	DRAWN
CHECKED	CHECKED
ENGR	ENGR
TERMIN ACTIVITY	TERMIN ACTIVITY
SCALE	SCALE
SHEET	SHEET
REV.	REV.

DATE	DATE
APPROVALS	APPROVALS
DRAWN	DRAWN
CHECKED	CHECKED
ENGR	ENGR
TERMIN ACTIVITY	TERMIN ACTIVITY
SCALE	SCALE
SHEET	SHEET
REV.	REV.

DATE	DATE
APPROVALS	APPROVALS
DRAWN	DRAWN
CHECKED	CHECKED
ENGR	ENGR
TERMIN ACTIVITY	TERMIN ACTIVITY
SCALE	SCALE
SHEET	SHEET
REV.	REV.

DATE	DATE
APPROVALS	APPROVALS
DRAWN	DRAWN
CHECKED	CHECKED
ENGR	ENGR
TERMIN ACTIVITY	TERMIN ACTIVITY
SCALE	SCALE
SHEET	SHEET
REV.	REV.

DATE	DATE
APPROVALS	APPROVALS
DRAWN	DRAWN
CHECKED	CHECKED
ENGR	ENGR
TERMIN ACTIVITY	TERMIN ACTIVITY
SCALE	SCALE
SHEET	SHEET
REV.	REV.

ENGINEERING PARTS LIST

ITEM	REV	PART NO.	DESCRIPTION	QTY	REFERENCE
1		601855-050	CON-CAB-PLG50CP.	3	J200-J202
2		602092-001	CONT, SGMC, MALE CRIMP	131	W/J200-J202
3		523999	WRTEF-STR22G-9-9-9	A/R	
4		602193-010	CON-CAB-RCP010C.100S	30	J100-J129
5		602199-001	CONTACT, CRIMP, RECEPT, 28-22GA	300	W/J100-J129
6		610777	TIE-CA-LKG-.062-.075	A/R	
7		910541	POLYURETHANE CONF. COAT	A/R	

RACAL Instruments™ Inc., 4 Goodyear St., Irvine, CA 92718				
DOCUMENT TITLE	SIZE	CODE NO	DOCUMENT NO	REV
HARNESS ASSEMBLY, 1260-16, TTI	A	21793	407436	B
DRN			SHEET	2 Of 17

ENGINEERING WIRE LIST

WIRE	FROM	TO	TYPE	PART	WIRE LEN	REFERENCE
	BLK AAx RW 01 (J100)	Uxx-SLOT yy (J200)	CABLE	407436		SYSTEM WIRE LIST
	BLK AAx RW 02 (J101)	Uxx-SLOT yy (J200)	CABLE	407436		
	BLK AAx RW 03 (J102)	Uxx-SLOT yy (J200)	CABLE	407436		
	BLK AAx RW 04 (J103)	Uxx-SLOT yy (J200)	CABLE	407436		
	BLK AAx RW 05 (J104)	Uxx-SLOT yy (J200)	CABLE	407436		
	BLK AAx RW 06 (J105)	Uxx-SLOT yy (J200)	CABLE	407436		
	BLK AAx RW 07 (J106)	Uxx-SLOT yy (J200,J201)	CABLE	407436		
	BLK AAx RW 08 (J107)	Uxx-SLOT yy (J200,J201)	CABLE	407436		
	BLK AAx RW 09 (J108)	Uxx-SLOT yy (J200,J201)	CABLE	407436		
	BLK AAx RW 10 (J109)	Uxx-SLOT yy (J200,J201)	CABLE	407436		
	BLK AAx RW11 (J110)	Uxx-SLOTyy (J200,J201)	CABLE	407436		
	BLK AAx RW 12 (J111)	Uxx-SLOT yy (J200,J201)	CABLE	407436		
	BLK AAx RW 13 (J112)	Uxx-SLOT yy (J201)	CABLE	407436		
	BLK AAx RW 14 (J113)	Uxx-SLOT yy (J201)	CABLE	407436		
	BLK AAx RW 15 (J114)	Uxx-SLOT yy (J201,J202)	CABLE	407436		
	BLK AAx RW 16 (J115)	Uxx-SLOT yy (J201)	CABLE	407436		
	BLK AAx RW 17 (J116)	Uxx-SLOT yy (J201)	CABLE	407436		
	BLK AAx RW 18 (J117)	Uxx-SLOT yy (J201)	CABLE	407436		
	BLK AAx RW 19 (J118)	Uxx-SLOT yy (J201,J202)	CABLE	407436		
	BLK AAx RW 20 (J119)	Uxx-SLOT yy (J201,J202)	CABLE	407436		
	BLK AAx RW 21 (J120)	Uxx-SLOT yy (J200-J202)	CABLE	407436		
	BLK AAx RW 22 (J121)	Uxx-SLOT yy (J201,J202)	CABLE	407436		
	BLK AAx RW 23 (J122)	Uxx-SLOT yy (J201,J202)	CABLE	407436		
	BLK AAx RW 24 (J123)	Uxx-SLOT yy (J201,J202)	CABLE	407436		
	BLK AAx RW 25 (J124)	Uxx-SLOT yy (J202)	CABLE	407436		

RACAL Instruments™ Inc., 4 Goodyear St., Irvine, CA 92718

DOCUMENT TITLE	SIZE	CODE NO	DOCUMENT NO	REV
HARNESS ASSEMBLY, 1260-16, TTI	A	21793	407436	B
	DRN		SHEET 3 Of 17	

ENGINEERING WIRE LIST

WIRE	FROM	TO	TYPE	PART	WIRE LEN	REFERENCE
	BLK AAx RW 26 (J125)	Uxx-SLOT yy (J202)	CABLE	407436		
	BLK AAx RW 27 (J126)	Uxx-SLOT yy (J201,J202)	CABLE	407436		
	BLK AAx RW 28 (J127)	Uxx-SLOT yy (J202)	CABLE	407436		
	BLK AAx RW 29 (J128)	Uxx-SLOT yy (J202)	CABLE	407436		
	BLK AAx RW 30 (J129)	Uxx-SLOT yy (J202)	CABLE	407436		

This system wirelist serves as a template for incorporating this harness assembly into the overall system wirelist. It does not in any way affect the fabrication of this harness assembly.

RACAL Instruments™, Inc., 4 Goodyear St., Irvine, CA 92718				
DOCUMENT TITLE	SIZE	CODE NO	DOCUMENT NO	REV
HARNESS ASSEMBLY, 1260-16, TTI	A	21793	407436	B
DRN			SHEET	4 Of 17

ENGINEERING WIRE LIST

WIRE	FROM	TO	TYPE	PART	WIRE LEN	REFERENCE
1	3100-1 602199-001	J200-Y 602092-001	22AWG WHT	523999	40 "	N.C.0
2	3101-1 602199-001	J100-1 (w/WIRE 1)	22AWG WHT	523999	4 "	N.C.0
3	3100-2 602199-001	J200-Z 602092-001	22AWG WHT	523999	40 "	N.C.1
4	3101-2 602199-001	J100-2 (w/WIRE 3)	22AWG WHT	523999	4 "	N.C.1
5	3100-3 602199-001	J200-S 602092-001	22AWG WHT	523999	40 "	N.C.2
6	3101-3 602199-001	J100-3 (w/WIRE 5)	22AW6 WHT	523999	4 "	N.C.2
7	3100-4 602199-001	J200-T 602092-001	22AWG WHT	523999	40 "	N.C.3
8	3101-4 602199-001	J100-4 (w/WIRE 7)	22AW6 WHT	523999	4 "	N.C.3
9	3100-5 602199-001	J200-K 602092-001	22AWG WHT	523999	40 "	N.C.4
10	3101-5 602199-001	J100-5 (w/WIRE 9)	22AWG WHT	523999	4 "	N.C.4
11	3100-6 602199-001	J200-L 602092-001	22AWG WHT	523999	40 "	N.C.5
12	3101-6 602199-001	J100-6 (w/WIRE 11)	22AW6 WHT	523999	4 "	N.C.5
13	3100-7 602199-001	J200-C 602092-001	22AW6 WHT	523999	40 "	N.C.6
14	3101-7 602199-001	J100-7 (w/WIRE 13)	22AWG WHT	523999	4 "	N.C.6
15	3100-8 602199-001	J200-D 602092-001	22AWG WHT	523999	40 "	N.C.7
16	3101-8 602199-001	J100-8 (w/WIRE 15)	22AW6 WHT	523999	4 "	N.C.7
17	3100-9 602199-001	NO CONNECT				
18	3101-9 602199-001	NOCONNECT				
19	3100-10 602199-001	NOCONNECT				
20	3101-10 602199-001	NOCONNECT				
21	3102-1 602199-001	J200-a 602092-001	22AWG WHT	523999	40 "	COM.0
22	3103-1 602199-001	J102-1 (w/WIRE 21)	22AWG WHT	523999	4 "	COM.0
23	3102-2 602199-001	J200-b 602092-001	22AW6 WHT	523999	40 "	COM.1
24	3103-2 602199-001	J102-2 (w/WIRE 23)	22AWG WHT	523999	4 '	COM.1

RACAL Instruments™, Inc., 4 Goodyear St., Irvine, CA 92718

DOCUMENT TITLE	SIZE	CODE NO	DOCUMENT NO	REV
HARNESS ASSEMBLY, 1260-16, TTI	A	21793	407436	B
	DRN		SHEET 5 Of 17	

ENGINEERING WIRE LIST

WIRE	FROM	TO	TYPE	PART	WIRE LEN	REFERENCE
25	J102-3 602199-001	J200-U 602092-001	22AW6 WHT	523999	40"	COM. 2
26	J103-3 602199-001	J102-3 (w/WIRE 25)	22AW6 WHT	523999	4"	COM. 2
27	J102-4 602199-001	J200-V 602092-001	22AWG WHT	523999	40"	COM. 3
28	J103-4 602199-001	J102-4 (w/WIRE 27)	22AWG WHT	523999	4"	COM. 3
29	J102-5 602199-001	J200-M 602092-001	22AWG WHT	523999	40"	COM. 4
30	J103-5 602199-001	J102-5 (w/WIRE 29)	22AW6 WHT	523999	4"	COM. 4
31	J102-6 602199-001	J200-N 602092-001	22AWG WHT	523999	40"	COM. 5
32	J103-6 602199-001	J102-6 (w/WIRE 31)	22AW6 WHT	523999	4"	COM. 5
33	J102-7 602199-001	J200-E 602092-001	22AWG WHT	523999	40"	COM. 6
34	J103-7 602199-001	J102-7 (w/WIRE 33)	22AWG WHT	523999	4"	COM. 6
35	J102-8 602199-001	J200-F 602092-001	22AWG WHT	523999	40"	COM. 7
36	J103-8 602199-001	J102-8 (w/WIRE 35)	22AWG WHT	523999	4"	COM. 7
37	J102-9 602199-001	J200-A 602092-001	22AW6 WHT	532999	40"	MUX. CH. 0-7
38	J103-9 602199-001	NO CONNECT				
39	J102-10 602199-001	J200-B 602092-001	22AW6 WHT	532999	40"	CHASSIS GND
40	J103-10 602199-001	NOCONNECT				
41	J104-1 602199-001	J200-c 602092-001	22AWG WHT	523999	40"	N.O. 0
42	J105-1 602199-001	J104-1 (w/WIRE 41)	22AWG WHT	523999	4"	N.O. 0
43	J104-2 602199-001	J200-d 602092-001	22AWG WHT	523999	40"	N.O. I
44	J105-2 602199-001	J104-2 (w/WIRE 43)	22AW6 WHT	523999	4"	N.O. 1
45	J104-3 602199-001	J200-W 602092-001	22AW6 WHT	523999	40"	N.O. 2
46	J105-3 602199-001	J104-3 (w/WIRE 45)	22AW6 WHT	523999	4"	N.O. 2
47	J104-4 602199-001	J200-X 602092-001	22AW6 WHT	523999	40"	N.O. 3
48	J105-4 602199-001	J104-4 (w/WIRE 47)	22AW6 WHT	523999	4"	N.O. 3
RACAL Instruments™, Inc., 4 Goodyear St., Irvine, CA 92718						
DOCUMENT TITLE			SIZE	CODE NO	DOCUMENT NO	REV
HARNESS ASSEMBLY, 1260-16, TTI			A	21793	407436	B
DRN					SHEET 6 Of 17	

ENGINEERING WIRE LIST

WIRE	FROM	TO	TYPE	PART	WIRE LEN	REFERENCE
49	J104-5 602199-001	J200-P 602092-001	22AWG WHT	523999	40 "	N.O. 4
50	J105-5 602199-001	J104-5 (w/WIRE 49)	22AWG WHT	523999	4 "	N.O. 4
51	J104-6 602199-001	J200-R 602092-001	22AW6 WHT	523999	40 "	N.O. 5
52	J105-6 602199-001	J104-6 (w/WIRE 51)	22AWG WHT	523999	4 "	N.O.S
53	J104-7 602199-001	J200-H 602092-001	22AW6 WHT	523999	40 "	N.O. 6
54	J105-7 602199-001	J104-7 (w/WIRE 53)	22AWG WHT	523999	4 "	N.O. 6
55	J104-8 602199-001	J200-3 602092-001	22AW6 WHT	523999	40 "	N.O. 7
56	J105-8 602199-001	J104-8 (w/WIRE 55)	22AWG WHT	523999	4 "	N.O. 7
57	J104-9 602199-001	NO CONNECT				
58	J105-9 602199-001	NO CONNECT				
59	J104-10 602199-001	NO CONNECT				
60	J105-10 602199-001	NO CONNECT				
61	J106-1 60219-901	J201-C 602092-001	22AW6 WHT	523999	40 "	N.C. 8
62	J107-1 602199-001	J106-1 (w/WIRE 61)	22AWG WHT	523999	4 "	N.C. 8
63	J106-2 602199-001	J201-D 602092-001	22AW6 WHT	523999	40 "	N.C. 9
64	J107-2 602199-001	J106-2 (w/WIRE 63)	22AW6 WHT	523999	4 "	N.C. 9
65	J106-3 602199-001	J200-z 602092-001	22AWG WHT	523999	40 "	N.C. 10
66	J107-3 602199-001	J106-3 (w/WIRE 65)	22AW6 WHT	523999	4 "	N.C. 10
67	J106-4 602199-001	J200-AA 602092-001	22AWG WHT	523999	40 "	N.C. 11
68	J107-4 602199-001	J106-4 (w/WIRE 67)	22AWG WHT	523999	4 "	N.C. 11
69	J106-5 602199-001	J200-t 602092-001	22AWG WHT	523999	40 "	N.C. 12
70	J107-5 602199-001	J106-5 (w/WIRE 69)	22AW6 WHT	523999	4 "	N.C. 12
71	J106-6 602199-001	J200-u 602092-001	22AWG WHT	523999	40 "	N.C. 13
72	J107-6 602199-001	J106-6 (w/WIRE 71)	22AWG WHT	523999	4 "	N.C. 13

RACAL Instruments™, Inc., 4 Goodyear St., Irvine, CA 92718

DOCUMENT TITLE	SIZE	CODE NO	DOCUMENT NO	REV
HARNESS ASSEMBLY, 1260-16, TTI	A	21793	407436	B
DRN			SHEET 7 Of 17	

ENGINEERING WIRE LIST

WIRE	FROM	TO	TYPE	PART	WIRE LEN	REFERENCE
73	J106-7 602199-001	J200-k 602092-001	22AWG WHT	523999	40"	N.C.14
74	J107-7 602199-001	J106-7 (w/WIRE 73)	22AW6 WHT	523999	4"	N.C.14
75	J106-8 602199-001	J200-m 602092-001	22AWG WHT	523999	40"	N.C.15
76	J107-8 602199-001	J106-8 (w/WIRE 75)	22AWG WHT	523999	4"	N.C.15
77	J106-9 602199-001	NO CONNECT				
78	J107-9 602199-001	NO CONNECT				
79	J106-10 602199-001	NO CONNECT				
80	J107-10 602199-001	NO CONNECT				
81	J108-1 602199-001	J201-E 602092-001	22AWG WHT	523999	40"	COM.8
82	J109-1 602199-001	J108-1 (w/WIRE 81)	22AWG WHT	523999	4"	COM.8
83	J108-2 602199-001	J201-F 602092-001	22AWG WHT	523999	40"	COM.9
84	J109-2 602199-001	J108-2 (w/WIRE 83)	22AWG WHT	523999	4"	COM.9
85	J108-3 602199-001	J200-BB 602092-001	22AWG WHT	523999	40"	COM.10
86	J109-3 602199-001	J108-3 (w/WIRE 85)	22AWG WHT	523999	4"	COM.10
87	J108-4 602199-001	J200-CC 602092-001	22AW6 WHT	523999	40"	COM.11
88	J109-4 602199-001	J108-4 (w/WIRE 87)	22AWG WHT	523999	4"	COM.11
89	J108-5 602199-001	J200-v 602092-001	22AWG WHT	523999	40"	COM.12
90	J109-5 602199-001	J108-5 (w/WIRE 89)	22AWG WHT	523999	4"	COM.12
91	J108-6 602199-001	J200-w 602092-001	22AWG WHT	523999	40"	COM.13
92	J109-6 602199-001	J108-6 (w/WIRE 91)	22AWG WHT	523999	4"	COM.13
93	J108-7 602199-001	J200-n 602092-001	22AWG WHT	523999	40"	COM.14
94	J109-7 602199-001	J108-7 (w/WIRE 93)	22AWG WHT	523999	4"	COM.14
95	J108-8 602199-001	J200-p 602092-001	22AW6 WHT	523999	40"	COM.15
96	J109-8 602199-001	J108-8 (w/WIRE 95)	22AWG WHT	523999	4"	COM.15

RACAL Instruments™, Inc., 4 Goodyear St., Irvine, CA 92718

DOCUMENT TITLE	SIZE	CODE NO	DOCUMENT NO	REV
HARNESS ASSEMBLY, 1260-16, TTI	A	21793	407436	B
	DRN		SHEET 8 Of 17	

ENGINEERING WIRE LIST

WIRE	FROM	TO	TYPE	PART #	WIRE LEN	REFERENCE
97	J108-9 602199-001	J200-h 602092-001	22AWG WHT	532999	40 "	MUX. CH. 8-15
98	J109-9 602199-001	NO CONNECT				
99	J108-10 602199-001	J201-B 602092-001	22AWG WHT	532999	40 "	CHASSIS GND
100	J109-10 602199-001	NOCONNECT				
101	J110-1 602199-001	J201-H 602092-001	22AWG WHT	523999	40 "	N.O.8
102	J111-1 602199-001	J110-1 (w/WIRE 101)	22AWG WHT	523999	4 "	N.O.8
103	J110-2 602199-001	J201-3 602092-001	22AWG WHT	523999	40 "	N.O.9
104	J111-2 602199-001	J110-2 (w/WIRE 103)	22AWG WHT	523999	4 "	NO.9
105	J110-3 602199-001	J200-DD 602092-001	22AWG WHT	523999	40 "	N.O.10
106	J111-3 602199-001	J110-3 (w/WIRE 105)	22AWG WHT	523999	4 "	N.O.10
107	J110-4 602199-001	J200-EE 602092-001	22AWG WHT	523999	40 "	N.O.11
108	J111-4 602199-001	J110-4 (w/WIRE 107)	22AWG WHT	523999	4 "	N.O.11
109	J110-5 602199-001	J200-x 602092-001	22AWG WHT	523999	40 "	N.O.12
110	J111-5 602199-001	J110-5 (w/WIRE 109)	22AWG WHT	523999	4 "	N.O.12
111	J110-6 602199-001	J200-y 602092-001	22AWG WHT	523999	40 "	N.O.13
112	J111-6 602199-001	J110-6 (w/WIRE 111)	22AWG WHT	523999	4 "	N.O.13
113	J110-7 602199-001	J200-r 602092-001	22AWG WHT	523999	40 "	N.O.14
114	J111-7 602199-001	J110-7 (w/WIRE 113)	22AWG WHT	523999	4 "	N.O.14
115	J110-8 602199-001	J200-s 602092-001	22AWG WHT	523999	40 "	N.O.15
116	J111-8 602199-001	J110-8 (w/WIRE 115)	22AWG WHT	523999	4 "	N.O.15
117	J110-9 602199-001	NOCONNECT				
118	J111-9 602199-001	NOCONNECT				
119	J110-10 602199-001	NOCONNECT				
120	J111-10 602199-001	NOCONNECT				

RACAL Instruments™, Inc., 4 Goodyear St., Irvine, CA 92718

DOCUMENT TITLE	SIZE	CODE NO	DOCUMENT NO	REV
HARNESS ASSEMBLY, 1260-16, TTI	A	21793	407436	B
DRN			SHEET 9 Of 17	

ENGINEERING WIRE LIST

WIRE	FROM	TO	TYPE	PART #	WIRE LEN	REFERENCE
121	J112-1 60219-901	J201-n 602092-001	22AWG WHT	523999	40"	N.C.16
122	J113-1 602199-001	J112-1 (w/WIRE 121)	22AWG WHT	523999	4"	N.C.16
123	J112-2 602199-001	J201-p 602092-001	22AWG WHT	523999	40"	N.C.17
124	J113-2 602199-001	J112-2 (w/WIRE 123)	22AWG WHT	523999	4"	N.C.17
125	J112-3 602199-001	J201-e 602092-001	22AWG WHT	523999	40"	N.C.18
126	J113-3 602199-001	J112-3 (w/WIRE 125)	22AWG WHT	523999	4"	N.C.18
127	J112-4 602199-001	J201-f 602092-001	22AWG WHT	523999	40"	N.C.19
128	J113-4 602199-001	J112-4 (w/WIRE 127)	22AWG WHT	523999	4"	N.C.19
129	J112-5 602199-001	J201-Y 602092-001	22AWG WHT	523999	40"	N.C.20
130	J113-5 602199-001	J112-5 (w/WIRE 129)	22AWG WHT	523999	4"	N.C.20
131	J112-6 602199-001	J201-Z 602092-001	22AWG WHT	523999	40"	N.C.21
132	J113-6 602199-001	J112-6 (w/WIRE 131)	22AWG WHT	523999	4"	N.C.21
133	J112-7 602199-001	J201-S 602092-001	22AWG WHT	523999	40"	N.C.22
134	J113-7 602199-001	J112-7 (w/WIRE 133)	22AWG WHT	523999	4"	N.C.22
135	J112-8 602199-001	J201-T 602092-001	22AWG WHT	523999	40"	N.C.23
136	J113-8 602199-001	J112-8 (w/WIRE 135)	22AWG WHT	523999	4"	N.C.23
137	J112-9 602199-001	NOCONNECT				
138	J113-9 602199-001	NOCONNECT				
139	J112-10 602199-001	NOCONNECT				
140	J113-10 602199-001	NOCONNECT				
141	J114-1 602199-001	J201-r 602092-001	22AWG WHT	523999	40"	COM.16
142	J115-1 602199-001	J114-1 (w/WIRE 141)	22AWG WHT	523999	4"	COM.16
143	J114-2 602199-001	J201-s 602092-001	22AWG WHT	523999	40"	COM.17

RACAL Instruments™, Inc., 4 Goodyear St., Irvine, CA 92718

DOCUMENT TITLE	SIZE	CODE NO	DOCUMENT NO	REV
HARNESS ASSEMBLY, 1260-16, TTI	A	21793	407436	B
	DRN		SHEET 10 Of 17	

ENGINEERING WIRE LIST

WIRE	FROM	TO	TYPE	PART	WIRE LEN	REFERENCE
144	J115-2 602199-001	J114-2 (w/WIRE 143)	22AWG WHT	523999	4"	COM.17
145	J114-3 602199-001	J201-h 602092-001	22AWG WHT	523999	40"	COM.18
146	J115-3 602199-001	J114-3 (w/WIRE 145)	22AWG WHT	523999	4"	COM.18
147	J114-4 602199-001	J201-j 602092-001	22AWG WHT	523999	40"	COM.19
148	J115-4 602199-001	J114-4 (w/WIRE 147)	22AWG WHT	523999	4"	COM.19
149	J114-5 602199-001	J201-a 602092-001	22AWG WHT	523999	40"	COM.20
150	J115-5 602199-001	J114-5 (w/WIRE 149)	22AWG WHT	523999	4"	COM.20
151	J114-6 602199-001	J201-b 602092-001	22AWG WHT	523999	40"	COM.21
152	J115-6 602199-001	J114-6 (w/WIRE 151)	22AWG WHT	523999	4"	COM.21
153	J114-7 602199-001	J201-U 602092-001	22AWG WHT	523999	40"	COM.22
154	J115-7 602199-001	J114-7 (w/WIRE 153)	22AWG WHT	523999	4"	COM.22
155	J114-8 602199-001	J201-V 602092-001	22AWG WHT	523999	40"	COM.23
156	J115-8 602199-001	J114-8 (w/WIRE 155)	22AWG WHT	523999	4"	COM.23
157	J114-9 602199-001	J201-x 602092-001	22AWG WHT	532999	40"	MUX. CH. 16-23
158	J115-9 602199-001	NO CONNECT				
159	J114-10 602199-001	J202-B 602092-001	22AWG WHT	532999	40"	CHASSIS GND
160	J115-10 602199-001	NO CONNECT				
161	J116-1 602199-001	J201-t 602092-001	22AWG WHT	523999	40"	N.O.16
162	J117-1 602199-001	J116-1 (w/WIRE 161)	22AWG WHT	523999	4"	N.O.16
163	J116-2 602199-001	J201-u 602092-001	22AWG WHT	523999	40"	N.O.17
164	J117-2 602199-001	J116-2 (w/WIRE 163)	22AWG WHT	523999	4"	N.O.17
165	J116-3 602199-001	J201-k 602092-001	22AWG WHT	523999	40"	N.O.18
166	J117-3 602199-001	J116-3 (w/WIRE 165)	22AWG WHT	523999	4"	N.O.18
167	J116-4 602199-001	J201-m 602092-001	22AWG WHT	523999	40"	N.O.19
RACAL Instruments™, Inc., 4 Goodyear St., Irvine, CA 92718						
DOCUMENT TITLE			SIZE	CODE NO	DOCUMENT NO	REV
HARNESS ASSEMBLY, 1260-16, TTI			A	21793	407436	B
DRN					SHEET 11 Of 17	

ENGINEERING WIRE LIST

WIRE	FROM	TO	TYPE	PART	WIRE LEN	REFERENCE
168	J117-4 602199-001	J116-4 (w/WIRE 167)	22AWG WHT	523999	4"	N.O.19
169	J116-5 602199-001	J201-c 602092-001	22AWG WHT	523999	40"	N.O.20
170	J117-5 602199-001	J116-5 (w/WIRE 169)	22AWG WHT	523999	4"	N.O.20
171	J116-6 602199-001	J201-d 602092-001	22AWG WHT	523999	40"	N.O.21
172	J117-6 602199-001	J116-6 (w/WIRE 171)	22AWG WHT	523999	4"	N.O.21
173	J116-7 602199-001	J201-W 602092-001	22AWG WHT	523999	40"	N.O.22
174	J117-7 602199-001	J116-7 (w/WIRE 173)	22AWG WHT	523999	4"	N.O.22
175	J116-8 602199-001	J201-X 602092-001	22AWG WHT	523999	40"	N.O.23
176	J117-8 602199-001	J116-8 (w/WIRE 175)	22AWG WHT	523999	4"	N.O.23
177	J116-9 602199-001	NO CONNECT				
178	J117-9 602199-001	NO CONNECT				
179	J116-10 602199-001	NO CONNECT				
180	J117-10 602199-001	NO CONNECT				
181	J118-1 60219-901	J202-S 602092-001	22AWG WHT	523999	40"	N.C.24
182	J119-1 602199-001	J118-1 (w/WIRE 181)	22AWG WHT	523999	4"	N.C.24
183	J118-2 602199-001	J202-T 602092-001	22AWG WHT	523999	40"	N.C.25
184	J119-2 602199-001	J118-2 (w/WIRE 183)	22AWG WHT	523999	4"	N.C.25
185	J118-3 602199-001	J202-K 602092-001	22AWG WHT	523999	40"	N.C.26
186	J119-3 602199-001	J118-3 (w/WIRE 185)	22AWG WHT	523999	4"	N.C.26
187	J118-4 602199-001	J202-L 602092-001	22AWG WHT	523999	40"	N.C.27
188	J119-4 602199-001	J118-4 (w/WIRE 187)	22AWG WHT	523999	4"	N.C.27
189	J118-5 602199-001	J202-C 602092-001	22AWG WHT	523999	40"	N.C.28
190	J119-5 602199-001	J118-5 (w/WIRE 189)	22AWG WHT	523999	4"	N.C.28
191	J118-6 602199-001	J202-D 602092-001	22AWG WHT	523999	40"	N.C.29

RACAL Instruments™, Inc., 4 Goodyear St., Irvine, CA 92718

DOCUMENT TITLE	SIZE	CODE NO	DOCUMENT NO	REV
HARNESS ASSEMBLY, 1260-16, TTI	A	21793	407436	B
DRN			SHEET 12 Of 17	

ENGINEERING WIRE LIST

WIRE	FROM	TO	TYPE	PART	WIRE LEN	REFERENCE
192	J119-6 602199-001	J118-6 (w/WIRE 191)	22AWG WHT	523999	4"	N.C. 29
193	J118-7 602199-001	J201-z 602092-001	22AWG WHT	523999	40"	N.C. 30
194	J119-7 602199-001	J118-7 (w/WIRE 193)	22AWG WHT	523999	4"	N.C. 30
195	J118-8 602199-001	J101-AA 602092-001	22AWG WHT	523999	40"	N.C. 31
196	J119-8 602199-001	J118-8 (w/WIRE 195)	22AWG WHT	523999	4"	N.C. 31
197	J118-9 602199-001	NO CONNECT				
198	J119-9 602199-001	NO CONNECT				
199	J118-10 602199-001	NO CONNECT				
200	J119-10 602199-001	NO CONNECT				
201	J120-1 602199-001	J202-U 602092-001	22AWG WHT	523999	40"	COM. 24
202	J121-1 602199-001	J120-1 (w/WIRE 201)	22AWG WHT	523999	4"	COM. 24
203	J120-2 602199-001	J202-V 602092-001	22AWG WHT	523999	40"	COM. 25
204	J121-2 602199-001	J120-2 (w/WIRE 203)	22AWG WHT	523999	4"	COM. 25
205	J120-3 602199-001	J202-M 602092-001	22AWG WHT	523999	40"	COM. 26
206	J121-3 602199-001	J120-3 (w/WIRE 205)	22AWG WHT	523999	4"	COM. 26
207	J120-4 602199-001	J202-N 602092-001	22AWG WHT	523999	40"	COM. 27
208	J121-4 602199-001	J120-4 (w/WIRE 207)	22AWG WHT	523999	4"	COM. 27
209	J120-5 602199-001	J202-E 602092-001	22AWG WHT	523999	40"	COM. 28
210	J121-5 602199-001	J120-5 (w/WIRE 209)	22AWG WHT	523999	4"	COM. 28
211	J120-6 602199-001	J202-F 602092-001	22AWG WHT	523999	40"	COM. 29
212	J121-6 602199-001	J120-6 (w/WIRE 211)	22AWG WHT	523999	4"	COM. 29
213	J120-7 602199-001	J201-BB 602092-001	22AW6 WHT	523999	40"	COM. 30
214	J121-7 602199-001	J120-7 (w/WIRE 213)	22AWG WHT	523999	4"	COM. 30
215	J120-8 602199-001	J201-CC 602092-001	22AWG WHT	523999	40"	COM. 31

RACAL Instruments™, Inc., 4 Goodyear St., Irvine, CA 92718

DOCUMENT TITLE	SIZE	CODE NO	DOCUMENT NO	REV
HARNESS ASSEMBLY, 1260-16, TTI	A	21793	407436	B
	DRN		SHEET	13 Of 17

ENGINEERING WIRE LIST

WIRE	FROM	TO	TYPE	PART	WIRE LEN	REFERENCE
216	J121-8 602199-001	J120-8 (w/WIRE 215)	22AWG WHT	523999	4"	COM. 31
217	J120-9 602199-001	J201-P 602092-001	22AWG WHT	532999	40"	MUX. CH. 24-31
218	J121-9 602199-001	NO CONNECT				
219	J120-10 602199-001	J200-HH 602092-001	22AWG WHT	532999	40"	CHASSIS GND
220	J121-10 602199-001	NO CONNECT				
221	J122-1 602199-001	J202-W 602092-001	22AWG WHT	523999	40"	N.O. 24
222	J123-1 602199-001	J122-1 (w/WIRE 221)	22AWG WHT	523999	4"	N.O. 24
223	J122-2 602199-001	J202-X 602092-001	22AWG WHT	523999	40"	N.O. 25
224	J123-2 602199-001	J122-2 (w/WIRE 223)	22AWG WHT	523999	4"	N.O. 25
225	J122-3 602199-001	J202-P 602092-001	22AWG WHT	523999	40"	N.O. 26
226	J123-3 602199-001	J122-3 (w/WIRE 225)	22AWG WHT	523999	4"	N.O. 26
227	J122-4 602199-001	J202-R 602092-001	22AWG WHT	523999	40"	N.O. 27
228	J123-4 602199-001	J122-4 (w/WIRE 227)	22AWG WHT	523999	4"	N.O. 27
229	J122-5 602199-001	J202-H 602092-001	22AWG WHT	523999	40"	N.O. 28
230	J123-5 602199-001	J122-5 (w/WIRE 229)	22AWG WHT	523999	4"	N.O. 28
231	J122-6 602199-001	J202-3 602092-001	22AWG WHT	523999	40"	N.O. 29
232	J123-6 602199-001	J122-6 (w/WIRE 231)	22AWG WHT	523999	4"	N.O. 29
233	3122-7 602199-001	J201-DD 602092-001	22AWG WHT	523999	40"	N.O. 30
234	3123-7 602199-001	J122-7 (w/WIRE 233)	22AWG WHT	523999	4"	N.O. 30
235	3122-8 602199-001	J201-EE 602092-001	22AWG WHT	523999	40"	N.O. 31
236	3123-8 602199-001	J122-8 (w/WIRE 235)	22AWG WHT	523999	4"	N.O. 31
237	3122-9 602199-001	NO CONNECT				
238	3123-9 602199-001	NO CONNECT				
239	3122-10 602199-001	NO CONNECT				

RACAL Instruments™, Inc., 4 Goodyear St., Irvine, CA 92718

DOCUMENT TITLE	SIZE	CODE NO	DOCUMENT NO	REV
HARNESS ASSEMBLY, 1260-16, TTI	A	21793	407436	B
	DRN		SHEET 14 Of 17	

ENGINEERING WIRE LIST

WIRE	FROM	TO	TYPE	PART	WIRE LEN	REFERENCE
240	J123-10 602199-001	NO CONNECT				
241	J124-1 60219-901	J202-z 602092-001	22AWG WHT	523999	40"	N.C. 32
242	J125-1 602199-001	J124-1 (w/WIRE 241)	22AWG WHT	523999	4"	N.C. 32
243	J124-2 602199-001	J202-AA 602092-001	22AWG WHT	523999	40"	N.C. 33
244	J125-2 602199-001	J124-2 (w/WIRE 243)	22AWG WHT	523999	4"	N.C. 33
245	J124-3 602199-001	J202-t 602092-001	22AWG WHT	523999	40"	N.C. 34
246	J125-3 602199-001	J124-3 (w/WIRE 245)	22AWG WHT	523999	4"	N.C. 34
247	J1244 602199-001	J202-u 602092-001	22AWG WHT	523999	40"	N.C. 35
248	J125-4 602199-001	J124-4 (w/WIRE 247)	22AWG WHT	523999	4"	N.C. 35
249	J124-5 602199-001	J202-k 602092-001	22AWG WHT	523999	40"	N.C. 36
250	J125-5 602199-001	J124-5 (w/WIRE 249)	22AWG WHT	523999	4"	N.C. 36
251	J124-6 602199-001	J202-m 602092-001	22AWG WHT	523999	40"	N.C. 37
252	J125-6 602199-001	J124-6 (w/WIRE 251)	22AWG WHT	523999	4"	N.C. 37
253	J124-7 602199-001	J202-c 602092-001	22AWG WHT	523999	40"	N.C. 38
254	J125-7 602199-001	J124-7 (w/WIRE 253)	22AWG WHT	523999	4"	N.C. 38
255	J124-8 602199-001	J202-d 602092-001	22AWG WHT	523999	40"	N.C. 39
256	J125-8 602199-001	J124-8 (w/WIRE 255)	22AWG WHT	523999	4"	N.C. 39
257	J124-9 602199-001	NO CONNECT				
258	J125-9 602199-001	NO CONNECT				
259	J124-10 602199-001	NO CONNECT				
260	J125-10 602199-001	NO CONNECT				
261	J126-1 602199-001	J202-BB 602092-001	22AWG WHT	523999	40"	COM. 32
262	J127-1 602199-001	J126-1 (w/WIRE 261)	22AWG WHT	523999	4"	COM. 32
RACAL Instruments™, Inc., 4 Goodyear St., Irvine, CA 92718						
DOCUMENT TITLE			SIZE	CODE NO	DOCUMENT NO	REV
HARNESS ASSEMBLY, 1260-16, TTI			A	21793	407436	B
			DRN		SHEET	15 Of 17

ENGINEERING WIRE LIST

WIRE	FROM	TO	TYPE	PART	WIRE LEN	REFERENCE
263	J126-2 602199-001	J202-CC 602092-001	22AWG WHT	523999	40"	COM. 33
264	J127-2 602199-001	J126-2 (w/WIRE 263)	22AWG WHT	523999	4"	COM. 33
265	J126-3 602199-001	J202-v 602092-001	22AWG WHT	523999	40"	COM. 34
266	J127-3 602199-001	J126-3 (w/WIRE 265)	22AWG WHT	523999	4"	COM. 34
267	J126-4 602199-001	J202-w 602092-001	22AWG WHT	523999	40"	COM. 35
268	J127-4 602199-001	J126-4 (w/WIRE 267)	22AWG WHT	523999	4"	COM. 35
269	J126-5 602199-001	J202-n 602092-001	22AWG WHT	523999	40"	COM. 36
270	J127-5 602199-001	J126-5 (w/WIRE 269)	22AWG WHT	523999	4"	COM. 36
271	J126-6 602199-001	J202-p 602092-001	22AWG WHT	523999	40"	COM. 37
272	J127-6 602199-001	J126-6 (w/WIRE 271)	22AWG WHT	523999	4"	COM. 37
273	J126-7 602199-001	J202-e 602092-001	22AWG WHT	523999	40"	COM. 38
274	J127-7 602199-001	J126-7 (w/WIRE 273)	22AWG WHT	523999	4"	COM. 38
275	J126-8 602199-001	J202-f 602092-001	22AWG WHT	523999	40"	COM. 39
276	J127-8 602199-001	J126-8 (w/WIRE 275)	22AWG WHT	523999	4"	COM. 39
277	J126-9 602199-001	J202-Y 602092-001	22AWG WHT	532999	40"	MUX. CH. 32-39
278	J127-9 602199-001	NO CONNECT				
279	J126-10 602199-001	J201-HH 602092-001	22AWG WHT	532999	40"	CHASSIS GND
280	J127-10 602199-001	NO CONNECT				
281	J128-1 602199-001	3202-DD 602092-001	22AWG WHT	523999	40"	N.O. 32
282	J129-1 602199-001	3128-1 (w/WIRE 281)	22AWG WHT	523999	4"	N.O. 32
283	J128-2 602199-001	3202-EE 602092-001	22AWG WHT	523999	40"	N.O. 33
284	J129-2 602199-001	3128-2 (w/WIRE 283)	22AWG WHT	523999	4"	N.O. 33
285	J128-3 602199-001	3202-x 602092-001	22AWG WHT	523999	40"	N.O. 34
286	J129-3 602199-001	3128-3 (w/WIRE 285)	22AWG WHT	523999	4"	N.O. 34
RACAL Instruments™, Inc., 4 Goodyear St., Irvine, CA 92718						
DOCUMENT TITLE			SIZE	CODE NO	DOCUMENT NO	REV
HARNESS ASSEMBLY, 1260-16, TTI			A	21793	407436	B
DRN					SHEET 16 Of 17	

ENGINEERING WIRE LIST

WIRE	FROM	TO	TYPE	PART #	WIRE LEN	REFERENCE
287	J128-4 602199-001	J202-y 602092-001	22AWG WHT	523999	40 "	N.O. 35
288	J129-4 602199-001	J128-4 (w/WIRE 287)	22AWG WHT	523999	4 "	N.O. 35
289	J128-5 602199-001	J202-r 602092-001	22AWG WHT	523999	40 "	N.O. 36
290	J129-5 602199-001	J128-5 (w/WIRE 289)	22AWG WHT	523999	4 "	N.O. 36
291	J128-6 602199-001	J202-s 602092-001	22AWG WHT	523999	40 "	N.O. 37
292	J129-6 602199-001	J128-6 (w/WIRE 291)	22AWG WHT	523999	4 "	N.O. 37
293	J128-7 602199-001	J202-h 602092-001	22AWG WHT	523999	40 "	N.O. 38
294	J129-7 602199-001	J128-7 (w/WIRE 293)	22AWG WHT	523999	4 "	N.O. 38
295	J128-8 602199-001	J202-j 602092-001	22AWG WHT	523999	40 "	N.O. 39
296	J129-8 602199-001	J128-8 (w/WIRE 295)	22AWG WHT	523999	4 "	N O. 39
297	J128-9 602199-001	NO CONNECT				
298	J129-9 602199-001	NO CONNECT				
299	J128-10 602199-001	J202-HH 602092-001	WHT 22AWG	523999	40 "	CHASSIS GND
300	J129-10 602199-001	NO CONNECT				

RACAL Instruments™, Inc., 4 Goodyear St., Irvine, CA 92718				
DOCUMENT TITLE	SIZE	CODE NO	DOCUMENT NO	REV
HARNESS ASSEMBLY, 1260-16, TTI	A	21793	407436	B
	DRN		SHEET	17 Of 17

Chapter 6

PRODUCT SUPPORT

Product Support

EADS North America Defense Test and Services, Inc. has a complete Service and Parts Department. If you need technical assistance or should it be necessary to return your product for repair or calibration, call 1-800-722-3262. If parts are required to repair the product at your facility, call 1-949-859-8999 and ask for the Parts Department.

When sending your instrument in for repair, complete the form in the back of this manual.

For worldwide support and the office closest to your facility, refer to the website for the most complete information <http://www.eads-nadefense.com>.

Warranty

Use the original packing material when returning the 1260-16 to EADS North America Defense Test and Services, Inc. for calibration or servicing. The original shipping container and associated packaging material will provide the necessary protection for safe reshipment.

If the original packing material is unavailable, contact EADS North America Defense Test and Services, Inc. Customer Service at 1-800-722-3262 for information.

REPAIR AND CALIBRATION REQUEST FORM

To allow us to better understand your repair requests, we suggest you use the following outline when calling and include a copy with your instrument to be sent to the EADS North America Defense Test and Service, Inc. Repair Facility.

Model _____ Serial No. _____ Date _____

Company Name _____ Purchase Order # _____

Billing Address _____

City

State/Province

Zip/Postal Code

Country

Shipping Address _____

City

State/Province

Zip/Postal Code

Country

Technical Contact _____ Phone Number () _____

Purchasing Contact _____ Phone Number () _____

1. Describe, in detail, the problem and symptoms you are having. Please include all set up details, such as input/output levels, frequencies, waveform details, etc.

2. If problem is occurring when unit is in remote, please list the program strings used and the controller type.

3. Please give any additional information you feel would be beneficial in facilitating a faster repair time (i.e., modifications, etc.)

4. Is calibration data required? Yes No (please circle one)

Call before shipping
 Note: We do not accept
 "collect" shipments.

Ship instruments to nearest support office.